

NETZSCH

Proven Excellence.



Accessories for Differential Scanning Calorimeters and Thermobalances

Crucibles, Sensors, Sample Carriers, Calibration Kits
for DSC, TGA and STA Systems

Analyzing & Testing

Introduction

Accessories for Thermal Analysis – DSC/DTA, TGA and STA

At NETZSCH, we always strive to be a step ahead. We place as much importance on the development and production of accessories as on that of new instruments. Accessories in contact with the sample or in close proximity to it require special attention. Potential reactions between the sample material and instrument parts must be prevented while ensuring that the test results remain reliable and accurate. For these reasons, one of our primary areas of focus is crucibles and sensors for DTA/DSC, TGA and STA instruments.

This catalogue provides an overview of all such crucibles and sensors for DTA, DSC, TGA and STA measurements. You will find many different crucible materials listed, and a variety of types and special shapes. From among these, we can help you find the right crucible size and material for any application, be it standard or special. In addition to standard aluminum crucibles, our portfolio includes autoclaves with low to medium or high pressure-tightness, as well as ones for determining the oxidative-induction time (OIT) and solid fat index (SFI). We offer crucibles made of ceramics or metals covering a wide temperature range. In the high-temperature range, special TGA and DTA crucibles, slip-on plates, meshes and baskets are available to accommodate specific sample dimensions and densities.

Lately, the demand for special crucibles has been increasing. Of course, measurements can only be carried out when the right sensor or sample carrier for these special crucibles is available. We have therefore listed these special cases here, often providing application examples to demonstrate their characteristic advantages.

Our accessories can open up a world of possibilities for your thermoanalytical needs. It is our hope that this catalogue will serve to acquaint you with these. If you have any questions, or if you require something specific which you cannot find in the following tables, please simply contact us – NETZSCH welcomes the challenge of working out a solution tailored to your application, and we are always happy to hear from you.



Crucibles	4	Sensors and Sample Carriers	35
Selection of Crucibles	4	DSC 204 F1 Phoenix [®] and DSC 204 F1 Nevio Sensors, TG 309 Libra [®] /TG 209 F1 Iris [®] / Libra [®] , TG 209 F1/F3 Nevio and TG 209 F3 Tarsus [®] Sample Carriers	36
DSC 300 Caliris [®] /DSC 204 F1 Phoenix [®] /DSC 200 F3 Maia [®] / DSC 3500 Sirius /DSC 214 Polyma , DSC 214 Nevio , DSC 204 F1 Nevio	5	DTA and DSC Sensors for the DSC 404 F1/F3 Pegasus [®]	38
Standard Crucibles made of Aluminum	6	TGA Sample Carriers and TGA-DTA Sensors for the STA 449 F1/F3 Jupiter [®] , STA 449 F3 Nevio	40
Crucibles for General and Special Applications	7	TGA-DTA and TGA-DSC Sensors for the STA 449 F1/F3 Jupiter [®] , STA 449 F3 Nevio	42
Sealing Press, Sample Preparation and Pressure-Tight Crucibles	9	Radiation Shield for STA Systems	44
Crucibles for Operation with the Automatic Sample Changer (ASC) for 20 Sample Pans	11	TGA and TGA-DSC Sensors for C _p Determination and Operation with the Automatic Sample Changer (ASC) for the STA 449 F1/F3 Jupiter [®] , STA 449 F3 Nevio	46
Crucibles for Operation with the Automatic Sample Changer (ASC) for 64 Sample Pans	13	Special Sample Carriers for Special Applications – OTS [®]	48
Crucibles for Operation with the Automatic Sample Changer (ASC) for 204 Sample Pans	15	Hanging Samples	49
TG 309 Libra [®] /TG 209 F1 Libra [®] /TG 209 F3 Tarsus [®] , TG 209 F1/F3 Nevio	17	Calibration	50
Crucibles for General Applications	17	Calibration Materials	51
Crucibles for Operation with the Automatic Sample Changer (ASC) for 64 Sample Pans	18	Calibration Kits for DSC and DTA	52
Crucibles for Operation with the Automatic Sample Changer for 204 Sample Pans – Applications	20	Calibration Kits for TGA and STA	55
Crucibles for Operation with the Automatic Sample Changer (ASC) for 20 Sample Pans	22	Chemical Behavior of Pt, Al ₂ O ₃ , Graphite, BN and ZrO ₂ Crucibles and Sensors	57
STA 2500 Regulus	23	Special Crucibles for Special Applications – BN and ZrO ₂	59
STA F1/F3/F5 Jupiter [®] , STA 449 F3 Nevio and DSC 404 F1/F3 Pegasus [®]	25	Material Compatibility – Sample in Crucible	60
Crucibles Made of Aluminum.....	25	Recommendations for Cleaning Al ₂ O ₃ and Pt Crucibles	62
DSC Crucibles for Measurements in a Pressure-Tight Environment	27		
Large TGA Crucibles and Slip-On Plates	28		
Knudsen Cells (TGA); TGA and TGA-DTA Crucibles Through to the Highest Temperature Range.....	29		
TGA-DTA, DSC and TGA-DSC Crucibles	31		
Crucibles for Automatic Sample Changer (ASC)	33		

Table of Contents

Crucibles

Crucibles and Their Selection

Crucibles and their lids are made of materials resistant to high temperatures, usually porcelain or an inert metal. Ceramics such as alumina, zirconia, and especially magnesia will tolerate the highest temperatures. One of the first metals used in crucible production was platinum; more recently, metals such as nickel and zirconium have also been used. The type of crucible used for thermo-analytical measurements can have a strong influence on the measurement results obtained. Additionally, the crucible can also influence the characteristics of the instrument's measuring cell.

Important Factors for Selection of Suitable DSC, TGA and STA Crucibles for Your Sample

- The DSC crucible should have a flat bottom and be made of a material with a high thermal conductivity. This guarantees optimum heat transfer and low temperature gradients between the sample, crucible and sensor.
- The crucible should be made of an inert material in order to prevent reactions with the sample in the programmed temperature range. Exceptions are crucibles for which a catalytic effect on the sample is desired (e.g., copper crucible for OIT tests, etc.).
- The crucible should not exhibit any phase transitions or other effects in the programmed temperature range; the melting point or fusion temperature must exceed the maximum application temperature to a sufficient degree.
- The dimension, shape and specific heat of the crucible should be optimized to achieve and/or maintain the highest caloric sensitivity and lowest time constant for the measuring system. Optimized parameters will result in sharp, well-defined and clearly separated peaks.
- Crucibles should be reusable, especially special ones for specific applications.



Standard Aluminum Crucibles

Crucibles for the DSC 300 *Caliris*[®], DSC 204 **F1** *Phoenix*[®], DSC 200 **F3** *Maia*[®], DSC 3500 *Sirius* and DSC 214 *Polyma*

The following tables list the crucibles for the low-temperature DSC systems. Many of these crucibles can also be used for the high-temperature DSC and STA systems and can be found in those tables as well.

Please note that the temperatures listed indicate the maximum temperature ranges of the crucible material but not of the DSC systems.

The premium *Concavus* pans have a unique geometry which features a concave bottom.

For special applications such as boiling point determination for volatile substances or gypsum investigations, Al lids with a laser-cut hole (50 μm) can be used. The lids can be cold-welded to the standard Al crucible.

Our high pressure crucibles are capable of withstanding a maximum of 100 bar of internal pressure. A single sealing tool handles the job identically for all high-pressure crucible varieties.

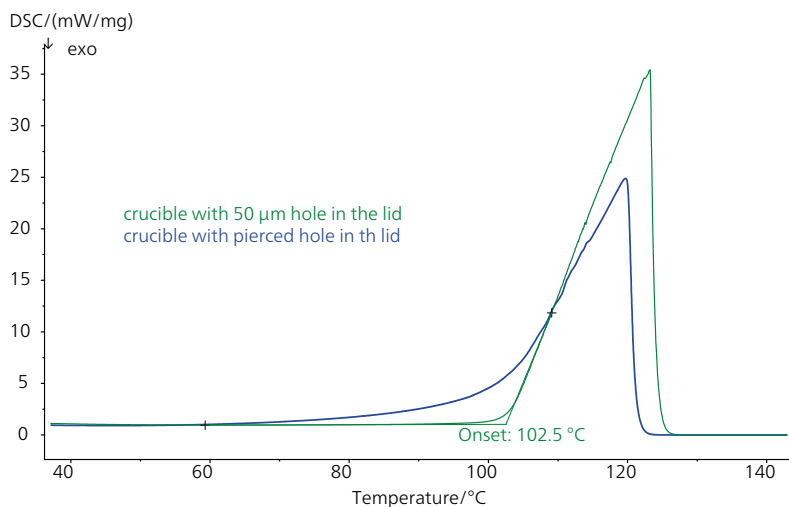

Using Al crucibles and lid with laser-cut hole (\varnothing 50- μm hole) suppresses evaporation of solvents and other volatiles. Furthermore, these lids can be used for gypsum investigations.

Al Lid with Laser-Cut Hole

Evaporation of volatile substances usually starts before the boiling point of the volatile is reached. This measurement shows that the evaporation of water can be suppressed by using a cold weldable aluminum lid with a defined hole (\varnothing 50 μm , green curve). The comparison measurement uses a lid with a punched hole. Here, evaporation already begins at slightly above 60°C (blue curve). Cold weldable lids with laser-cut holes can also be used for gypsum applications. The separation of dihydrate (DH) and half hydrate (HH) can be achieved.

**Standard Crucibles Made of Aluminum for the DSC 300 *Caliris*®, DSC 204 *F1 Phoenix*®, DSC 200 *F3 Maia*®,
DSC 3500 *Sirius*, DSC 214 *Polyma* , DSC 214 *Nevio*, DSC 204 *F1 Nevio***

Material (Purity)	Temperature Range	Consisting of	Dimension/ Volume	Remarks	Order Number
Al (99.5)	Max. 600°C	Crucible + lid	ø 6 mm; 25/40 µl*	Set of 100 pcs., cold weldable**	6.239.2-64.5.00
Al (99.5)	Max. 600°C	Crucible + lid	ø 6 mm; 25/40 µl*	Set of 500 pcs., cold weldable**	6.239.2-64.51.00
Al (99.5)	Max. 600°C	Crucible	ø 6 mm; 25/40 µl*	100 pieces	6.239.2-64.5.01
Al (99.5)	Max. 600°C	Lid		Set of 100 pcs. for 6.239.2-64.5.01	6.239.2-64.5.02
Al (99.5)	Max. 600°C	Crucible + lid with laser-cut hole (50 µm)	ø 6 mm; 40 µl	Set of 100 pcs., cold weldable**	6.239.2-64.8.00
Al (99.5)	Max. 600°C	Crucible + lid with laser-cut hole (50 µm)	ø 6 mm; 40 µl	Set of 500 pcs., cold weldable**	6.239.2-64.81.00
Al (99.5)	Max. 600°C	Crucible + lid***	ø 5 mm; 30/40 µl	1 Set, 3in1 Box (archiving system)	DSC21400A66.010.00
Al (99.5)	Max. 600°C	Crucible + lid***	ø 5 mm; 30/40 µl	5 Sets of 96 pieces incl. 3in1 box	DSC21400A66.020-00
Al (99.5)	Max. 600°C	<i>Concavus</i> pan***	ø 5 mm; 30/40 µl	96 pieces including 3in1 box	NGB814672
Al (99.5)	Max. 600°C	Crucible + lid***	ø 5 mm; 30/40 µl	Set of <i>Concavus</i> pans and lids, 100 pieces each, without tray	DSC21400A66.030-00
Al (99.5)	Max. 600°C	Crucible + lid***	ø 5 mm; 30/40 µl	Set of <i>Concavus</i> pans and lids, 500 pieces each, without tray	DSC21400A66.040-00
Al (99.5)	Max. 600°C	Crucible + lid*** with lasercut hole (50 µm)	ø 5 mm; 30/40 µl	Set of 100 <i>Concavus</i> pcs. + lid, cold weldable**	DSC21400A66.050-00
Al (99.5)	Max. 600°C	Lid with laser-cut hole (50 µm)***		Pierced lids for <i>Concavus</i> crucibles, 100 pcs.	DSC21400A66.051-00
Al (99.5)	Max. 600°C	<i>Concavus</i> pan***	ø 5 mm; 30/40 µl	Set of 100 pcs.	NGB817525
Al (99.5)	Max. 600°C	<i>Concavus</i> lid***		Set of 100 pcs.	NGB817526
Al (99.5)	Max. 600°C	Slide-in lid		For <i>Concavus</i> pans; allows sample to be pressed onto crucible bottom, set of 100 pcs., especially for foils and fibers; requires tool kit DSC21400A80.030-00 for sealing press 6.240.10-80.0.00A	NGB815051
Al (99.5)	Max. 600°C	Crucible	ø 6.7mm; 85 µl	Set of 100 pieces	NGB810405
Al (99.5)	Max. 600°C	Set***		2 x 3in1 boxes, <i>Concavus</i> sealing tool, <i>Concavus</i> calibration set	DSC21400A91.010-00
Al (99.5)	Max. 600°C	Lid		100 pieces, for NGB810405	NGB810406

* Crucible volumes of either 25 µl or 40 µl can be achieved by simply reversing the lid.

** One and the same sealing press is capable of sealing all standard Al crucibles; order no. 6.240.10-80.0.00A.

*** Using *Concavus* pans with ASC instrument which were delivered before 2014 may require re-adjustment of the ASC gripper.



Crucibles for General and Special Applications

Crucibles for General Applications – DSC 300 *Caliris*®, DSC 204 *F1 Phoenix*®, DSC 200 *F3 Maia*®, DSC 3500 *Sirius*, DSC 214 *Polyma*, DSC 214 *Nevio*, DSC 204 *F1 Nevio*

Material (Purity)	Temp. Range	Consisting of	Dimension/ Volume	Remarks	Order Number
Al ₂ O ₃ (99.7)	Max. 1700°C	Crucible	ø 6.8 mm/85 µl		GB399972
Al ₂ O ₃ (99.7)	Max. 1700°C	Lid		For GB399972	GB399973
Fused silica	Max. 1000°C	Crucible	ø 6.7 mm/85 µl		GB399974
Fused silica	Max. 1000°C	Lid		For GB399974	GB399975
Pt/Rh (90/10)	Max. 1700°C	Crucible	ø 6.8 mm/85 µl		NGB825767
Pt/Rh (80/20)	Max. 1700°C	Crucible	ø 6.8 mm/190 µl		NGB801556
Pt/Rh (90/10)	Max. 1700°C	Lid		For NGB825767 and NGB801556	NGB825768
Gold (99.9)	Max. 900°C	Crucible + lid	ø 6.7 mm/85 µl		6.225.6-93.3.00
Silver	Max. 750°C	Crucible + lid	ø 6.7 mm/85 µl		6.225.6-93.4.00



Ampoules made of Duran glass or fused silica are available.

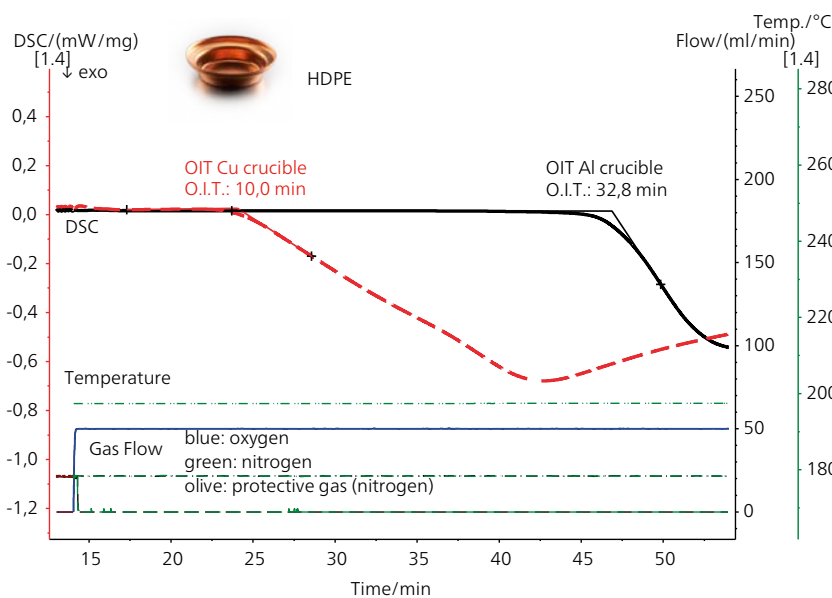

Influence of the Crucible on the Oxidative-Induction Time (OIT)

The oxidative-induction time (OIT) can be determined in standard aluminum or in open copper crucibles in accordance with ASTM D3895.

This plot represents an OIT measurement of HDPE carried out in open copper (red) and Al (black) crucible respectively. It can clearly be seen that, under isothermal conditions, oxidation of HDPE begins approximately 23 min earlier in the copper crucible than in the Al crucible.

Comparison of the oxidative-induction time in open copper and aluminum crucibles.

Special Crucibles for Special Applications – DSC 300 *Caliris*®, DSC 204 **F1** *Phoenix*®, DSC 200 **F3** *Maia*®, DSC 3500 *Sirius*, DSC 214 *Polyma* , DSC 214 *Nevio*, DSC 204 **F1** *Nevio*

Material (Purity)	Temperature Range	Consisting of	Dimension/ Volume	Remarks	Order Number
Cu	Max. 600°C	Crucible	ø 6 mm/25/40 µl	For OIT measurements according to ASTM D3895 (Oxidative-Induction Time), Set of 25	6.239.2-64.6.00
Duran glass	Max. 600°C	Ampoule	80 µl	Set of 100, not available for DSC 214 <i>Polyma</i> and DSC 214 <i>Nevio</i> , after sealing ampoule length ≈ 19 mm	6.240.1-93.2.00
Fused silica	Max. 1000°C	Ampoule	80 µl	After sealing ampoule length ≈ 19 mm	NGB815223
For DSC 204 F1 : Auxiliary kit for glass ampoules				<ul style="list-style-type: none"> Seal-off support for glass ampoules Small welder with butane and oxygen gas bottles Inner lid for measuring cell for use with glass ampoules 	6.240.10-93.1.00
For DSC 300 <i>Caliris</i> ® <i>Select/Supreme</i> with S-Module, DSC 300 <i>Caliris</i> ® <i>Classic</i> , DSC 200 F3 <i>Maia</i> ®: Auxiliary kit for glass ampoules				<ul style="list-style-type: none"> Seal-off support for glass ampoules Small welder with butane and oxygen gas bottles Inner lid for measuring cell for use with glass ampoules 100 ampoules 	6.240.20-93.1.00
For DSC 300 <i>Caliris</i> ® with H-Module or P-Module, DSC 204 F1 <i>Phoenix</i> ® with τ-sensor and DSC 214 <i>Polyma</i> : Al (99.5)	Max. 600°C	Crucible	ø 6.7 mm/85 µl	<p>Especially for determination of the OIT of lubricants and grease in accordance to ASTM D5483-5 and Solid Fat Index (SFI) in accordance to ASTM D6186</p> <p>Required accessories to obtain OIT/SFI crucible design:</p> <ul style="list-style-type: none"> Sealing press 6.240.10-80.0.00A Stamping toolkit 6.240.10-84.0.00 Lid NGB810406 	NGB810405



Special crucibles made of copper and aluminum for OIT tests

Sealing Press, Sample Preparation and Pressure-Tight Crucibles

Sealing Press/Tools

- The sealing press (order no. 6.240.10-80.0.00A) can be equipped with five toolkits for sealing and stamping of different crucible types:
 - Toolkit for *Concavus* pan: order no. 6.240.10-85.0.00
 - Toolkit for Al crucible: order no. 6.240.10-81.0.00
 - Toolkit for low-pressure Al crucibles 40µl and 100µl: order no. 6.240.10-86.0.00
 - Toolkit for sealing of medium-pressure crucibles: order no. 6.240.10-83.0.00
 - Stamping toolkit 6.240.10-84.0.00 for SFI crucible NGB810405
 - Toolkit for inserting slide in lid (order no. NGB815051) into *Concavus* pan: order no. DSC21400A80.030-00
- Sealing tool for the high-pressure crucibles, order no. 6.239.2-92.4.00



Sample Preparation

For the sample preparation, we offer two kits for the low- and high-temperature range:

- Kit for low-temperature range: cutting board, scissors, hollow punch, scribe, glass-fiber brush, tweezers, spatula, scalpel, 5 scalpel blades, 5 single-edge blades, ball pen, post-it, space for business card of the NETZSCH contact, manual order no. 6.240.12-99.0.00



- Kit for high-temperature range: cutting board, scissors hollow punch, scribe, glass-fiber brush, tweezers, spatula, scalpel, 5 scalpel blades, 5 single-edge blades, shaping tool, crucible holder, weighing support, crucible box with 4 Al₂O₃ crucibles, post-it, manual order no. DSC404F1A99.000-00



- *SampleCutter* tool for cutting and creating of plane-non-metallic samples (e.g., polymer granulates), order no. NGB814695
 - 10 spare blades for *SampleCutter*, order no. NGB 814821
- Crucible box with 10 positions for transport and storage of the samples during preparation; dimension of the positions: 10.5 mm x 10.5 mm x 5.2 mm, order no. NGB823922



Crucibles Made of Aluminum – Low-Pressure

Material (Purity)	Temperature Range	Consisting of	Dimension/ Volume	Remarks	Order Number
Al (99.5)	Max. 600°C	Crucible + Lid	ø 6 mm/40 µl; 3 bar	Set of 100 pieces, cold weldable	DSC21400A65.030-00
Al (99.5)	Max. 600°C	Crucible + Lid	ø 6 mm/40 µl; 3 bar	Set of 500 pieces, cold weldable	DSC21400A65.040-00
Al (99.5)	Max. 600°C	Crucible + Lid	ø 6 mm/100 µl; 3 bar	Set of 100 pieces, cold weldable	DSC21400A65.050-00
Al (99.5)	Max. 600°C	Crucible + Lid	ø 6 mm/100 µl; 3 bar	Set of 500 pieces, cold weldable	DSC21400A65.060-00
Al (99.5)	Max. 600°C	Crucible	ø 6 mm/40 µl; 3 bar	100 pieces	DSC21400A65.030-01
Al (99.5)	Max. 600°C	Crucible	ø 6 mm/100 µl; 3 bar	100 pieces	DSC21400A65.050-01
Al (99.5)	Max. 600°C	Lid	for crucibles of ø 6 mm	100 pieces	6.239.2-64.5.02

Medium- and High-Pressure Crucibles

Material (Purity)	Temperature Range	Consisting of	Dimension/ Volume	Remarks	Order Number
CrNi steel (AISI 304)	Max. 250°C	Crucible + lid + elastomer seal	120 µl; 20 bar	Set of 25 pieces; seal made of FPM	6.240.1-68.1.00
O-ring seal	Max. 230°C	O-ring	Max. 20 bar	Seal made of PCTFE	NGB801765
CrNi steel (AISI 316L)	Max. 500°C	Crucible + lid, hexagonal, gold-plated surface, reusable	ø 6 mm, 27 µl, max. 100 bar	1 crucible + 5 Au sealing disks (sealing press 6.239.2-92.4)	6.239.2-92.3.00
CrNi steel (AISI 316L)	Max. 500°C	Crucible + lid, hexagonal, gold-plated surface, reusable	ø 6 mm, 27 µl, max. 100 bar	10 crucibles + 50 Au sealing disks (sealing press 6.239.2-92.4)	6.239.2-92.31.00
CrNi steel (AISI 316L)	Max. 500°C	Crucible + lid, hexagonal, gold-plated surface, reusable	ø 6 mm, 100 µl, max. 100 bar	1 crucible + 5 Au sealing disks (sealing press 6.239.2-92.4)	6.239.2-92.8.00
CrNi steel (AISI 316L)	Max. 500°C	Crucible + lid, hexagonal, reusable	ø 6 mm, 27 µl, max. 100 bar	1 crucible + 5 Au sealing disks (sealing press 6.239.2-92.4)	6.239.2-93.3.00
CrNi steel (AISI 316L)	Max. 500°C	Crucible + lid, hexagonal, reusable	ø 6 mm, 27 µl, max. 100 bar	10 crucibles + 50 Au sealing disks (sealing press 6.239.2-92.4)	6.239.2-93.31.00
CrNi steel (AISI 316L)	Max. 500°C	Crucible + lid, hexagonal, reusable	ø 6 mm, 100 µl, max. 100 bar	1 crucible + 5 Au sealing disks (sealing press 6.239.2-92.4)	6.239.2-93.4.00
CrNi steel (AISI 316L)	Max. 500°C	Crucible + lid, hexagonal, reusable	ø 6 mm, 100 µl, max. 100 bar	10 crucible + 50 Au sealing disks (sealing press 6.239.2-92.4)	6.239.2-93.41.00
Titanium (Grade 4)	Max. 500°C	Crucible + lid, hexagonal, reusable	ø 6 mm, 27 µl, max. 100 bar	1 crucible + 5 Au sealing disks (sealing press 6.239.2-92.4)	6.239.2-92.6.00
Titanium (Grade 4)	Max. 500°C	Crucible + lid, hexagonal, reusable	ø 6 mm, 100 µl, max. 100 bar	1 crucible + 5 Au sealing disks (sealing press 6.239.2-92.4)	6.239.2-92.9.00
Au seals (Au 585)	Max. 500°C	For all high-pressure autoclaves; 100 pieces; alloy: Au 58.5%, Ag 26%, Cu 15.5%			6.240.1-91.1.00
Sealing press		For crucibles: 6.239.2-92.3.00, -92.31.00, -92.6.00, -92.8.00, -92.9.00, -93.3.00, -93.31.00, -93.4.00, -93.41.00			6.239.2-92.4.00



Medium-pressure crucible (right) and high-pressure crucible (left)

Crucibles for Operation with the Automatic Sample Changer (ASC) for 20 Sample Pans

Crucibles for DSC 200 **F3** *Maia*[®], DSC 3500 *Sirius*, DSC 214 *Polyma*,
DSC 214 *Nevio* and DSC 300 *Caliris*[®] *Classic* in ASC Operation

Crucible Material (Purity/%), Volume Lid	ASC Gripper DSC 200 F3	Carousel Standard Crucibles	Carousel Large Crucibles	Order Number
Al (99.5), 30/40 µl (<i>Concavus</i> pan)	x*	x	x	DSC21400A66.010-00 ¹ DSC21400A66.020-00 ¹ DSC21400A66.030-00 ¹ DSC21400A66.040-00 ¹ DSC21400A66.050-00 ¹ NGB817525
Crucible with welded lid	x*	x	x	
Al (99.5), 30/40µl, slide-in lid for <i>Convacus</i> pan	x	x	x	NGB815051
Al (99.5), 30/40 µl, crucible and lid with laser-cut-hole	x			DSC21400A66.050-00
Al (99.5), 25/40 µl	x	x	x	6.239.2-64.5.00
Crucible with welded lid	x	x	x	
Al (99.5), 25/40 µl (500/pkg.)	x	x	x	6.239.2-64.51.00
Crucible with welded lid	x	x	x	
Al (99.5), 25/40 µl	x	x	x	6.239.2-64.8.00
Crucible and lid with laser-cut-hole	x	x	x	
Al (99.5), 25/40 µl (500/pkg.)	x	x	x	6.239.2-64.81.00
Crucible and lid with laser-cut-hole	x	x	x	
Al (99.5), low pressure, 40µl (100/pkg.)	x	x	x	DSC21400A65.030-00
Al (99.5), low pressure, 40µl (500/pkg.)	x	x	x	DSC21400A65.040-00
Crucible 40µl with welded lid	x	x	x	
Al (99.5), low pressure, 100µl, (100/pkg.)	x ²	x	x	DSC21400A65.050-00
Al (99.5), low pressure, 100µl (500/pkg.)	x ²	x	x	DSC21400A65.060-00
Crucible 100µl with welded lid	x ²	x	x	
CrNi steel (AISI 304), medium- pressure, 120 µl, 20 bar	x	x	Only for manual operation	6.240.1-68.1.00
Crucible with lid	x	x		
Copper, 25 µl	x	x	Only for manual operation	6.239.2-64.6.00
CrNi steel (AISI 316L), high-pressure, 27 µl, gold-plated, 100 bar	x	x	Only for manual operation	6.239.2-92.3.00
CrNi steel (AISI 316L), high-pressure, 27 µl, 100 bar	x	x	Only for manual operation	6.239.2-93.3.00
CrNi (AISI 316L), high-pressure, 100 µl, gold-plated, 100 bar	x	x	Only for manual operation	6.239.2-92.8.00
CrNi (AISI 316L), high-pressure, 100 µl, 100 bar	x	x	Only for manual operation	6.239.2-93.4.00
Ti (Grade 4), high-pressure, 27 µl, 100 bar	x	x	Only for manual operation	6.239.2-92.6.00

¹ Please see crucible details on page 6

² Using low pressure crucibles 100µl, require specific adjustment of the ASC gripper.

Crucible Material (Purity/%), Volume Lid	ASC Gripper DSC 200 F3	Carousel Standard Crucibles	Carousel Large Crucibles	Order Number
Ti (Grade 4), high-pressure, 100 µl, 100 bar	x	x	Only for manual operation	6.239.2-92.9.00
Al ₂ O ₃ (99.7), ø 6.8 mm, 85 µl	x	x	Only for manual operation	GB399972
Crucible with lid (note: lid order no.)	x	x		GB399973
Fused silica, ø 6.8 mm, 85 µl	x	x	Only for manual operation	GB399974
Crucible with lid (note: lid order no.)	-	x		GB399975
Fused silica, ø 8 mm, 300 µl	x	-		NGB812506
Pt/Rh (90/10), ø 6.8 mm, 85 µl	x	x	Only for manual operation	NGB825767
Crucible with lid (note: lid order no.)	-	x		NGB825768
Pt/Rh (80/20), ø 6.8 x 6 mm, 190 µl	x	x	Only for manual operation	NGB801556
Crucible with lid (note: lid order no.)	-	x		NGB825768
Al (99.5), ø 6.7 mm, 85 µl	x	x	Only for manual operation	NGB810405
Crucible with lid (note: lid order no.)	-	x		NGB810406
Graphite, ø 6.8mm, 85 µl	x	x	Only for manual operation	GB399956
Crucible with lid (note: lid order no.)	-	x		GB399957
Gold (99.9), ø 6.8 mm, 85 µl,	x	x	Only for manual operation	6.225.6-93.3.00
Crucible with lid (99.9)	-	x		
Silver, ø 6.8 mm, 85 µl	x	x	Only for manual operation	6.225.6-93.4.00
Crucible with lid	-	x		
ZrO ₂ , ø 6.8mm, 85 µl	x	x	Only for manual operation	GB397053
Crucible with lid (note: lid order no.)	-	x		GB397052
Y ₂ O ₃ ¹ , ø 6.8mm, 85 µl	x	x	Only for manual operation	NGB812636
Crucible with lid ¹ (note: lid order no.)	x	x		NGB812635
MgO, ø 6.8mm, 85 µl	x	x	Only for manual operation	NGB812639
Crucible with lid (note: lid order no.)	x	x		NGB812637
Al ₂ O ₃ (99.7), ø 8 x 8 mm, 300 µl	x	-	x	NGB803698
Crucible with lid (note: lid order no.)	-	-	-	NGB808209
Pt/Rh/Al ₂ O ₃ system with lid	-	x	Only for manual operation	6.225.6-93.5.00

* Using *Concavus* pans with ASC instrument which were delivered before 2014 may require re-adjustment of the ASC gripper.

¹ May not be used with Al₂O₃, e.g., sensor plate, sapphire disc, etc.

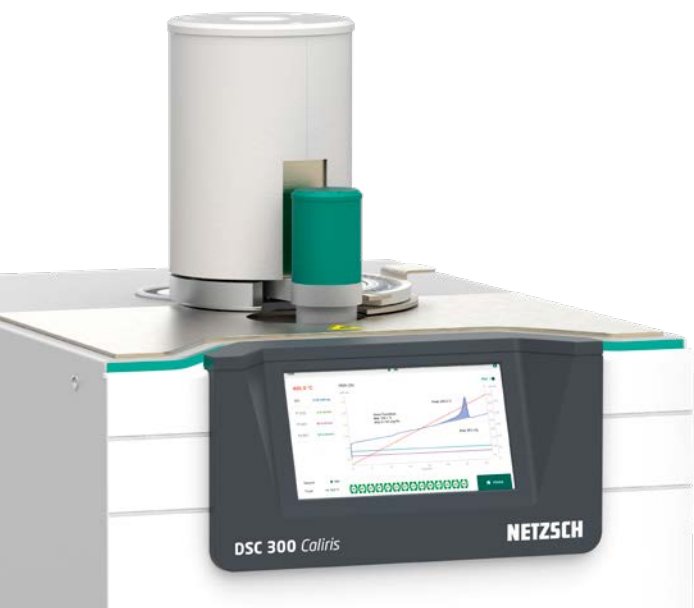

Concavus pans with lids, 30 µl or 40 µl

Crucibles for Operation with the Automatic Sample Changer (ASC) for 64 Sample Pans

Crucibles for DSC 204 F1 Phoenix in ASC Operation				
Crucible Material (Purity/%), Volume Lid	ASC Gripper DSC 200 F3	Carousel Standard Crucibles	Carousel Large Crucibles	Order Number
Al (99.5), 30/40 µl (Concavus pan)	x*	x	x	DSC21400A66.010-00 ¹
				DSC21400A66.020-00 ¹
				DSC21400A66.030-00 ¹
				DSC21400A66.040-00 ¹
				DSC21400A66.050-00 ¹ NGB817525
Crucible with welded lid	x*	x	x	
Al (99.5), 30/40µl, slide-in lid for Concavus pan	x	x	x	NGB815051
Al (99.5), 30/40 µl, crucible and lid with laser-cut-hole	x			DSC 21400A66.050-00
Al (99.5), 25/40 µl	x	x	x	6.239.2-64.5.00
Crucible with welded lid	x	x	x	
Al (99.5), 25/40 µl (500/pkg.)	x	x	x	6.239.2-64.51.00
Crucible with welded lid	x	x	x	
Al (99.5), 25/40 µl	x	x	x	6.239.2-64.8.00
Crucible and lid with laser-cut-hole	x	x	x	
Al (99.5), 25/40 µl (500/pkg.)	x	x	x	6.239.2-64.81.00
Crucible and lid with laser-cut-hole	x	x	x	
Al (99.5), low pressure, 40µl (100/pkg.)	x	x	x	DSC21400A65.030-00
Al (99.5), low pressure, 40µl (500/pkg.)	x	x	x	DSC21400A65.040-00
Crucible 40µl with welded lid	x	x	x	
Al (99.5), low pressure, 100µl, (100/pkg.)	x ²	x	x	DSC21400A65.050-00
Al (99.5), low pressure, 100µl (500/pkg.)	x ²	x	x	DSC21400A65.060-00
Crucible 100µl with welded lid	x ²	x	x	
CrNi steel (AISI 304), medium-pressure, 120 µl, 20 bar	-	x	Only for manual operation	6.240.1-68.1.00
Crucible with lid	-	x		
Copper, 25 µl	x	x	Only for manual operation	6.239.2-64.6.00
CrNi steel (AISI 316L), high-pressure, 27 µl, gold-plated, 100 bar	x	x	Only for manual operation	6.239.2-92.3.00
CrNi steel (AISI 316L), high-pressure, 27 µl, 100 bar	x	x	Only for manual operation	6.239.2-93.3.00
CrNi (AISI 316L), high-pressure, 100 µl, gold-plated, 100 bar	x	x	Only for manual operation	6.239.2-92.8.00
CrNi (AISI 316L), high-pressure, 100 µl, 100 bar	x	x	Only for manual operation	6.239.2-93.4.00

¹ Please see crucible details on page 6

² Using low pressure crucibles 100µl, require specific adjustment of the ASC gripper.

Crucible Material (Purity/%), Volume Lid	ASC Gripper DSC 200 F3	Carousel Standard Crucibles	Carousel Large Crucibles	Order Number
Ti (Grade 4), high-pressure, 27 µl, 100 bar	x	x	Only for manual operation	6.239.2-92.6.00
Ti (Grade 4), high-pressure, 100 µl, 100 bar	x	x	Only for manual operation	6.239.2-92.9.00
Al ₂ O ₃ (99.7), ø 6.8 mm, 85 µl	x	x	Only for manual operation	GB399972
Crucible with lid (note: lid order no.)	x	x		GB399973
Fused silica, ø 6.8 mm, 85 µl	x	x	Only for manual operation	GB399974
Crucible with lid (note: lid order no.)	-	x		GB399975
Fused silica, ø 8 mm, 300 µl	-	-	Only for manual operation	NGB812506
Pt/Rh (90/10), ø 6.8 mm, 85 µl	x	x	Only for manual operation	NGB825767
Crucible with lid (note: lid order no.)	-	x		NGB825768
Pt/Rh (80/20), ø 6.8 mm, 85 µl	x	x	Only for manual operation	NGB801556
Crucible with lid (note: lid order no.)	-	x		NGB825768
Al (99.5), ø 6.7 mm, 85 µl	x	x	Only for manual operation	NGB810405
Crucible with lid (note: lid order no.)	-	x		NGB810406
Graphite, ø 6.8 mm, 85 µl	x	x	Only for manual operation	GB399956
Crucible with lid	-	x		GB399957
Gold, ø 6.8 mm, 85 µl	x	x	Only for manual operation	6.225.6-93.3.00
Crucible with lid	-	x		
Silver, ø 6.8 mm, 85 µl	x	x	Only for manual operation	6.225.6-93.4.00
Crucible with lid (note: lid order no.)	-	x		
ZrO ₂ , ø 6.8 mm, 85 µl	x	x	Only for manual operation	GB397053
Crucible with lid (note: lid order no.)	-	x		GB397052
Y ₂ O ₃ , ¹ ø 6.8 mm, 85 µl	x	x	Only for manual operation	NGB812636
Crucible with lid ¹ (note: lid order no.)	x	x		NGB812635
MgO, ø 6.8 mm, 85 µl	x	x	Only for manual operation	NGB812639
Crucible with lid (note: lid order no.)	x	x		NGB812637
Al ₂ O ₃ (99.7), ø 8 x 8 mm, 300 µl	-	-	Only for manual operation	NGB803698
Crucible with lid (note: lid order no.)	-	-		NGB808209
Pt/Rh/Al ₂ O ₃ system with lid	-	x	Only for manual operation	6.225.6-93.5.00

* Using *Concavus* pans with ASC instrument which were delivered before 2014 may require re-adjustment of the ASC gripper.

¹ May not be used with Al₂O₃, e.g., sensor plate, sapphire disc, etc.

Crucibles for Operation with the Automatic Sample Changer (ASC) for 204 Sample Pans

Crucibles for DSC 300 *Caliris*® *Supreme* and *Select*, DSC 204 **F1** *Phoenix*® and DSC 204 **F1** *Nevio* for 204 Sample Pans, possible for τ -sensor

Crucible Material (Purity/%), Volume Lid	ASC Gripper	Order Number
Al (99.5), 30/40 μ l (<i>Concavus</i> pan)	x	DSC21400A66.010-00 ¹
		DSC21400A66.020-00 ¹
		DSC21400A66.030-00 ¹
		DSC21400A66.040-00 ¹
		DSC21400A66.050-001, NGB817525
Crucible with welded lid	x	
Al (99.5), 30/40 μ l, slide-in lid for <i>Concavus</i> pan	x	NGB815051
Al (99.5), 30/40 μ l, crucible and lid with laser-cut-hole	x	DSC21400A66.050-00
Al (99.5), 25/40 μ l	x	6.239.2-64.5.00
Crucible with welded lid	x	
Al (99.5), 25/40 μ l (500/pkg.)	x	6.239.2-64.51.00
Crucible with welded lid	x	
Al (99.5), 25/40 μ l	x	6.239.2-64.8.00
Crucible and lid with laser-cut-hole	x	
Al (99.5), low pressure, 40 μ l (100/pkg.)	x	DSC21400A65.030-00
Al (99.5), low pressure, 40 μ l (500/pkg.)	x	DSC21400A65.040-00
Crucible 40 μ l with welded lid	x	
Al (99.5), low pressure, 100 μ l, (100/pkg.)	x	DSC21400A65.050-00
Al (99.5), low pressure, 100 μ l (500/pkg.)	x	DSC21400A65.060-00
Crucible 100 μ l with welded lid	x	
Al (99.5), 25/40 μ l (500/pkg.)	x	6.239.2-64.81.00
Crucible and lid with laser-cut-hole	x	
CrNi steel (AISI 304), medium-pressure, 120 μ l, 20 bar	x	6.240.1-68.1.00
Crucible with lid	x	
Copper, 25 μ l	x	6.239.2-64.6.00
CrNi steel (AISI 316L), high-pressure, 27 μ l, gold-plated, 100 bar	x	6.239.2-92.3.00
CrNi steel (AISI 316L), high-pressure, 27 μ l, 100 bar	x	6.239.2-93.3.00
CrNi (AISI 316L), high-pressure, 100 μ l, gold-plated, 100 bar	x	6.239.2-92.8.00
CrNi (AISI 316L), high-pressure, 100 μ l, 100 bar	x	6.239.2-93.4.00
Ti (Grade 4), high-pressure, 27 μ l, 100 bar	x	6.239.2-92.6.00
Ti (Grade 4), high-pressure, 100 μ l, 100 bar	x	6.239.2-92.9.00
Al ₂ O ₃ (99.7), \varnothing 6.8 mm, 85 μ l	x	GB399972
Crucible with lid (note: lid order no.)	x	GB399973
Fused silica, \varnothing 6.8 mm, 85 μ l	x	GB399974
Crucible with lid (note: lid order no.)	x	GB399975
Fused silica, \varnothing 8 mm, 300 μ l	x	NGB812506
Pt/Rh (90/10), \varnothing 6.8 mm, 85 μ l	x	NGB825767
Crucible with lid (note: lid order no.)	x	NGB825768

¹ Please see crucible details on page 6

Crucible Material (Purity/%), Volume Lid	ASC Gripper	Order Number
Pt/Rh (80/20), ø 6.8 mm, 190 µl	x	NGB801556
Crucible with lid (note: lid order no.)	x	NGB825768
Al (99.5), ø 6.7 mm, 85 µl	x	NGB810405
Crucible with lid (note: lid order no.)	x	NGB810406
Graphite, ø 6.8 mm, 85 µl	x	GB399956
Crucible with lid	x	GB399957
Gold, ø 6.8 mm, 85 µl	x	6.225.6-93.3.00
Crucible with lid	x	
Silver, ø 6.8 mm, 85 µl	x	6.225.6-93.4.00
Crucible with lid	x	
ZrO ₂ , ø 6.8 mm, 85 µl	x	GB397053
Crucible with lid (note: lid order no.)	x	GB397052
Y ₂ O ₃ , ¹ ø 6.8 mm, 85 µl	x	NGB812636
Crucible with lid ¹ (note: lid order no.)	x	NGB812635
MgO, ø 6.8 mm, 85 µl	x	NGB812639
Crucible with lid (note: lid order no.)	x	NGB812637
Al ₂ O ₃ (99.7), ø 8 x 8 mm, 300 µl	x	NGB803698 ²
Crucible with lid (note: lid order no.)	x	NGB808209
Pt/Rh/Al ₂ O ₃ system with lid	x	6.225.6-93.5.00

¹ May not be used with Al₂O₃, e.g., sensor plate, sapphire disc, etc.

² May be used in the row for calibration materials or in the 96 sample tray without a sample pan in direct neighborhood



Crucibles for General Applications

Crucibles for the TG 309 *Libra*® Series, TG 209 *F1 Libra*® and TG 209 *F3 Tarsus*®

The TG 309 *Libra*®, TG 209 *F1 Libra*® and TG 209 *F3 Tarsus*® offer sample carriers for regular and large sample masses, guaranteeing broad applications in the temperature range from room temperature to 1000°C and 1100°C, respectively.

A large variety of crucibles is available to cover the temperature range for different materials, including large crucibles required for substances with a high sample mass and low density (e.g., foams, aerogels, etc.).

Crucibles for General Applications – TG 309 *Libra*®, TG 209 *F1 Libra*® and TG 209 *F1 Nevio*

Material (Purity/%)	Temperature Range	Consisting of	Dimension/ Volume	Remarks	Order Number
Al ₂ O ₃ (99.7)	Max. 1700°C	Crucible	ø 6.8 mm/85 µl		GB399972
Al ₂ O ₃ (99.7)	Max. 1700°C	Lid		For GB399972	GB399973
Fused silica	Max. 1000°C	Crucible	ø 6.8 mm/85 µl		GB399974
Fused silica	Max. 1000°C	Lid		For GB399974	GB399975
Pt/Rh (90/10)	Max. 1700°C	Crucible	ø 6.8 mm/85 µl		NGB825767
Pt/Rh (90/10)	Max. 1700°C	Lid		For NGB825767 and NGB801556	NGB825768
Pt/Rh (80/20)	Max. 1700°C	Crucible	ø 6.8 mm/190 µl		NGB801556
Al (99.5)	Max. 610°C	Crucible	ø 6.7 mm/85 µl	Set of 100 pieces	NGB810405
Al (99.5)	Max. 610°C	Lid		For NGB810405	NGB810406
Gold (99.9)	Max. 900°C	Crucible + lid	ø 6.7 mm/85 µl		6.225.6-93.3.00
Silver	Max. 750°C	Crucible + lid	ø 6.7 mm/85 µl		6.225.6-93.4.00
ZrO ₂	Max. 2000°C	Crucible	85 µl	CaO-stabilized	GB397053
ZrO ₂	Max. 2000°C	Lid		For GB397053	GB397052
Graphite	Max. 2200°C	Crucible	85 µl		GB399956
Graphite	Max. 2200°C	Lid		For GB399956	GB399957
Al ₂ O ₃ (99.8)	Max. 1700°C	Crucible	ø 9 mm, height 7 mm, volume 350 µl	Sample holder for large samples required	NGB800453
Al ₂ O ₃ (99.8)	Max. 1700°C	Lid			NGB800454
Al ₂ O ₃ (99.7)	Max. 1700°C	Crucible	ø 8 mm, height 8 mm, volume 300 µl	Sample holder for large samples required, ASC-compatible	NGB803698
Al ₂ O ₃ (99.7)	Max. 1700°C	Lid		For crucible NGB803698	NGB808209



Large crucible made of Al₂O₃, volume 350 µl



Large crucible made of Al₂O₃, volume 300 µl



Crucibles made of Pt

Crucibles for Operation with the Automatic Sample Changer (ASC) for 64 Sample Pans

Crucibles for TG 209 <i>F1 Libra</i> ® and TG 209 <i>F1 Nevio</i> in ASC Operation				
Crucible Material (Purity/%), Volume Lid	ASC Gripper	Carousel Standard Crucibles	Carousel Large Crucibles	Order Number
Al (99.5), 30/40 µl (<i>Concavus</i> pan)*	x*	x	x	DSC21400A66.010-00 ¹ DSC21400A66.020-00 ¹ DSC21400A66.030-00 ¹ DSC21400A66.040-00 ¹ DSC21400A66.050-00 ¹ NGB817525
Crucible with welded lid	x	x	x	
Al (99.5), 30/40µl, slide-in lid for <i>Convacus</i> pan	x	x	x	NGB815051
Al (99.5), 30/40 µl, crucible and lid with laser-cut-hole	x			DSC21400A66.050-00
Al (99.5), 25/40 µl	x	x	x	6.239.2-64.5.00
Crucible with welded lid	x	x	x	
Al (99.5), 25/40 µl	x	x	x	6.239.2-64.8.00
Crucible and lid with laser-cut-hole	x	x	x	
Al (99.5), low pressure, 40µl (100/pkg.)	x	x	x	DSC21400A65.030-00
Al (99.5), low pressure, 40µl (500/pkg.)	x	x	x	DSC21400A65.040-00
Crucible 40µl with welded lid	x	x	x	
Al (99.5), low pressure, 100µl, (100/pkg.)	x ²	x	x	DSC21400A65.050-00
Al (99.5), low pressure, 100µl (500/pkg.)	x ²	x	x	DSC21400A65.060-00
Crucible 100µl with welded lid	x ²	x	x	
CrNi steel (AISI 304), medium-pressure, 120 µl, 20 bar	-	x	Only for manual operation	6.240.1-68.1.00
Crucible with lid	-	x		
Copper, 25 µl	x	x	Only for manual operation	6.239.2-64.6.00
CrNi steel (AISI 316L), high-pressure, 27 µl, gold-plated, 100 bar	x	x	Only for manual operation	6.239.2-92.3.00
CrNi steel (AISI 316L), high-pressure, 27 µl, 100 bar	x	x	Only for manual operation	6.239.2-93.3.00
CrNi (AISI 316L), high-pressure, 100 µl, gold-plated, 100 bar	x	x	Only for manual operation	6.239.2-92.8.00
CrNi (AISI 316L), high-pressure, 100 µl, 100 bar	x	x	Only for manual operation	6.239.2-93.4.00
Ti (Grade 4), high-pressure, 27 µl, 100 bar	x	x	Only for manual operation	6.239.2-92.6.00
Ti (Grade 4), high-pressure, 100 µl, 100 bar	x	x	Only for manual operation	6.239.2-92.9.00

¹ Please see crucible details on page 6

² Using low pressure crucibles 100µl, require specific adjustment of the ASC gripper.

Crucible Material (Purity/%), Volume Lid	ASC Gripper	Carousel Standard Crucibles	Carousel Large Crucibles	Order Number
Al ₂ O ₃ (99.7), 6.8 mm, 85 µl	x	x	Only for manual operation	GB399972
Crucible with lid (note: lid order no.)	-	x		GB399973
Fused silica, ø 8 mm, 300 µl	-	-	x	NGB812506
Fused silica, ø 6.8 mm, 85 µl	x	x	Only for manual operation	GB399974
Crucible with lid (note: lid order no.)	-	x		GB399975
Pt/Rh (90/10), ø 6.8 mm, 85 µl	x	x	Only for manual operation	NGB825767
Crucible with lid (note: lid order no.)	-	x		NGB825768
Pt/Rh (80/20), ø 6.8 x 6 mm, 190 µl	x	x	Only for manual operation	NGB801556
Crucible with lid (note: lid order no.)	-	x		NGB825768
Al (99.5), ø 6.7 mm, 85 µl	x	x	Only for manual operation	NGB810405
Crucible with lid (note: lid order no.)	-	x		NGB810406
Graphite, ø 6.8 mm, 85 µl	x	x	Only for manual operation	GB399956
Crucible with lid (note: lid order no.)	-	x		GB399957
Gold, ø 6.8 mm, 85 µl	x	x	Only for manual operation	6.225.6-93.3.00
Crucible with lid	-	x		
Silver, ø 6.8 mm, 85 µl	x	x	Only for manual operation	6.225.6-93.4.00
Crucible with lid	-	x		
ZrO ₂ , ø 6.8 mm, 85 µl	x	x	Only for manual operation	GB397053
Crucible with lid (note: lid order no.)	-	x		GB397052
Y ₂ O ₃ ¹ , ø 6.8 mm, 85 µl	x	x	Only for manual operation	NGB812636
Crucible with lid ¹ (note: lid order no.)	x	x		NGB812635
MgO, ø 6.8 mm, 85 µl	x	x	Only for manual operation	NGB812639
Crucible with lid (note: lid order no.)	x	x		NGB812637
Al ₂ O ₃ (99.7), ø 8 x 8 mm, 300 µl	x	-	x	NGB803698
Crucible with lid (note: lid order no.)	-	-	x	NGB808209
Pt/Rh/Al ₂ O ₃ system with lid	-	x	Only for manual operation	6.225.6-93.5.00

* Using *Concavus* pans with ASC instrument which were delivered before 2014 may require re-adjustment of the ASC gripper.

¹ May not be used with Al₂O₃, e.g., sensor plate, sapphire disc, etc.

Crucibles for Operation with the Automatic Sample Changer (ASC) for 204 Sample Pans

Crucibles for TG 309 <i>Libra</i> ®, TG 209 <i>F1 Libra</i> ® and TG 209 <i>F1 Nevio</i> in ASC Operation		
Crucible Material (Purity/%), Volume Lid	ASC Gripper	Order Number
Al (99.5), 30/40 µl (<i>Concavus</i> pan)*	x	DSC21400A66.020-00 ¹ DSC21400A66.030-00 ¹ DSC21400A66.040-00 ¹ DSC21400A66.050-00 ¹ NGB817525
Crucible with welded lid	x	
Al (99.5), 30/40µl, slide-in lid for <i>Convacus</i> pan	x	NGB815051
Al (99.5), 30/40 µl, crucible and lid with laser-cut-hole	x	DSC21400A66.050-00
Al (99.5), 25/40 µl	x	6.239.2-64.5.00
Crucible with welded lid	x	
Al (99.5), 25/40 µl	x	6.239.2-64.8.00
Crucible and lid with laser-cut-hole	x	
Al (99.5), low pressure, 40µl (100/pkg.)	x	DSC21400A65.030-00
Al (99.5), low pressure, 40µl (500/pkg.)	x	DSC21400A65.040-00
Crucible 40µl with welded lid	x	
Al (99.5), low pressure, 100µl, (100/pkg.)	x	DSC21400A65.050-00
Al (99.5), low pressure, 100µl (500/pkg.)	x	DSC21400A65.060-00
Crucible 100µl with welded lid	x	
CrNi steel (AISI 304), medium-pressure, 120 µl, 20 bar	x	6.240.1-68.1.00
Crucible with lid	x	
Copper, 25 µl	x	6.239.2-64.6.00
CrNi steel (AISI 316L), high-pressure, 27 µl, gold-plated, 100 bar	x	6.239.2-92.3.00
CrNi steel (AISI 316L), high-pressure, 27 µl, 100 bar	x	6.239.2-93.3.00
CrNi (AISI 316L), high-pressure, 100 µl, gold-plated, 100 bar	x	6.239.2-92.8.00
CrNi (AISI 316L), high-pressure, 100 µl, 100 bar	x	6.239.2-93.4.00
Ti (Grade 4), high-pressure, 27 µl, 100 bar	x	6.239.2-92.6.00
Ti (Grade 4), high-pressure, 100 µl, 100 bar	x	6.239.2-92.9.00
Al ₂ O ₃ (99.7), 6.8 mm, 85 µl	x	GB399972
Crucible with lid (note: lid order no.)	x	GB399973
Fused silica, ø 6.8 mm, 85 µl	x	GB399974
Crucible with lid (note: lid order no.)	x	GB399975
Fused silica, ø 8 mm, 300 µl	x	NGB812506

¹ Please see crucible details on page 6

Crucible Material (Purity/%), Volume Lid	ASC Gripper	Order Number
Pt/Rh (90/10), ø 6.8 mm, 85 µl	x	NGB825767
Crucible with lid (note: lid order no.)	x	NGB825768
Pt/Rh (80/20), ø 6.8 x 6 mm, 190 µl	x	NGB801556
Crucible with lid (note: lid order no.)	x	NGB825768
Al (99.5), ø 6.7 mm, 85 µl	x	NGB810405
Crucible with lid (note: lid order no.)	x	NGB810406
Graphite, ø 6.8 mm, 85 µl	x	GB399956
Crucible with lid (note: lid order no.)	x	GB399957
Gold, ø 6.8 mm, 85 µl	x	6.225.6-93.3.00
Crucible with lid	x	
Silver, ø 6.8 mm, 85 µl	x	6.225.6-93.4.00
Crucible with lid	x	
ZrO ₂ , ø 6.8 mm, 85 µl	x	GB397053
Crucible with lid (note: lid order no.)	x	GB397052
Y ₂ O ₃ , ¹ ø 6.8 mm, 85 µl	x	NGB812636
Crucible with lid ¹ (note: lid order no.)	x	NGB812635
MgO, ø 6.8 mm, 85 µl	x	NGB812639
Crucible with lid (note: lid order no.)	x	NGB812637
Al ₂ O ₃ (99.7), ø 8 x 8 mm, 300 µl	x	NGB803698
Crucible with lid (note: lid order no.)	x	NGB808209
Pt/Rh/Al ₂ O ₃ system with lid	x	6.225.6-93.5.00

¹ May not be used with Al₂O₃, e.g., sensor plate, sapphire disc, etc.



Crucibles for Operation with the Automatic Sample Changer (ASC) for 20 Sample Pans – Applications

Crucibles for TG 309 <i>Libra</i> ® <i>Classic</i> , TG 209 F3 <i>Tarsus</i> ® and TG 209 F3 <i>Nevio</i> in ASC Operation				
Crucible Material (Purity/%), Volume Lid	ASC Gripper TG 209 F3 / TG 309 series	Carousel Standard Crucibles	Carousel Large Crucibles	Order Number
Al (99.5), 30/40 µl (<i>Concavus</i> pan)	x*	x	x	DSC21400A66.010.00 NGB817525
Crucible with welded lid	x	x	x	
Al (99.5), 30/40µl, slide-in lid for <i>Concavus</i> pan	x			NGB815051
Al (99.5), 30/40 µl, crucible and lid with laser-cut-hole	x			DSC21400A66.050-00
Al ₂ O ₃ (99.7), ø 6.8 mm, 85 µl	x	x	Only for manual operation	GB399972
Crucible with lid (note: lid order no.)	x	x		GB399973
Fused silica, ø 6.8 mm, 85 µl	x	x	Only for manual operation	GB399974
Crucible with lid (note: lid order no.)	-	x		GB399975
Pt/Rh (90/10), ø 6.8 mm, 85 µl	x	x	Only for manual operation	NGB825767
Crucible with lid (note: lid order no.)	-	x		NGB825768
Pt/Rh (80/20), ø 6.8 x 6 mm, 190 µl	x	x	Only for manual operation	NGB801556
Crucible with lid (note: lid order no.)	-	x		NGB825768
Al (99.5), ø 6.7 mm, 85 µl	x	x	Only for manual operation	NGB810405
Crucible with lid (note: lid order no.)	-	x		NGB810406
Graphite, ø 6.8mm, 85 µl	x	x	Only for manual operation	GB399956
Crucible with lid (note: lid order no.)	-	x		GB399957
Gold (99.9), ø 6.8 mm, 85 µl	x	x	Only for manual operation	6.225.6-93.3.00
Crucible with lid (99.9)	-	x		
Silver, ø 6.8 mm, 85 µl	x	x	Only for manual operation	6.225.6-93.4.00
Crucible with lid	-	x		
ZrO ₂ , ø 6.8mm, 85 µl	x	x	Only for manual operation	GB397053
Crucible with lid (note: lid order no.)	-	x		GB397052
Y ₂ O ₃ , ¹ ø 6.8mm, 85 µl	x	x	Only for manual operation	NGB812636
Crucible with lid ¹ (note: lid order no.)	x	x		NGB812635
MgO, ø 6.8mm, 85 µl	x	x	Only for manual operation	NGB812639
Crucible with lid (note: lid order no.)	x	x		NGB812637
Al ₂ O ₃ (99.7), ø 8 x 8 mm, 300 µl	x	-	x	NGB803698
Crucible with lid (note: lid order no.)	-	-	x	NGB808209
Pt/Rh/Al ₂ O ₃ system with lid	-	x	Only for manual operation	6.225.6-93.5.00

* Using *Concavus* pans with ASC instrument which were delivered before 2014 may require re-adjustment of the ASC gripper.

¹ May not be used with Al₂O₃, e.g., sensor plate, sapphire disc, etc.

Please note: Other crucibles suitable for ASC operation are listed in the ASC table for the DSC 200 **F3** *Maia*®, DSC 3500 *Sirius*, DSC 214 *Polyma* and DSC 303 *Caliris*® *Classic* see page 11

Crucibles for the STA 2500 *Regulus*



Cap-type lid made of alumina
order no. JA000981



Slip-on-plate

The STA 2500 *Regulus* is a standard simultaneous thermal analyzer with trend-setting technology. This top-loading unique differential balance arrangement is delivered with slip-on plates which allow for nearly all kinds of sample pans. A large slip-on plate is available for a large volume crucible.

Crucibles, Lids/Caps and Slip-on Plates for the STA 2500 *Regulus*

Material (Purity/%)	Temperature Range	Consisting of	Dimension/ (ø x Height)/ Volume	Remarks	Order Number
Al (99.5)	600°C	Crucible	ø 5.2 x 2.6 mm/45 µl	Set of 100 pieces	J1560179
Al (99.5)	600°C	Crucible	ø 5.2 x 5.1 mm/95 µl	Large crucible, set of 100 pieces	J1560180
Al (99.5)	600°C	Lid, drop-in type	ø 4.8 mm	For Al crucibles, Set of 100 pieces	J1560184
Al ₂ O ₃ (99.7)	1700°C	Crucible	ø 5.2 x 2.6 mm/40 µl	Set of 2 pieces	J1560181
Al ₂ O ₃ (99.7)	1700°C	Crucible	ø 5.2 x 5.1 mm/80 µl	Large crucible, set of 2 pieces	J1560182
Al ₂ O ₃ (99.7)	1700°C	Cap-type lid	ø 5.7 x 2.25 mm	For Al ₂ O ₃ crucibles J1560181 and J1560182, set of 2 pieces	JA000981
Pt(Pt90/Rh10)	1600°C	Crucible	ø 5.2 x 2.6 mm/45 µl	Set of 2 pieces	J5900905
Pt(Pt90/Rh10)	1600°C	Crucible	ø 5.2 x 5.1 mm/95 µl	Large crucible, set of 2 pieces	J5900879
Pt(Pt90/Rh10)	1600°C	Cap-type lid	ø 5.5 x 2.1 mm	Set of 2 pieces	JA000982
Pt(Pt90/Rh10)	1600°C	Lid, drop-in type	ø 4.8 mm	For Pt crucibles, set of 2 pieces	J5900906
Reshaping tool for Pt crucible					J7672306
Fused silica	1000°C	Crucible	ø 5.2 x 2.6 mm/25 µl	Set of 10 pieces	J5900881
Fused silica	1000°C	Crucible	ø 5.2 x 5.1 mm/55 µl	Large container, Set of 10 pieces	J1560183
Al ₂ O ₃ (99.7)	1700°C	Slip-on-plate		Standard, set of 2 pieces	JA003598
Al ₂ O ₃ (99.7)	1700°C	Flat slip-on plate	ø 6.8 mm	Set of 2 pieces, for crucibles with ø 6.8 mm	JA006844
Al ₂ O ₃ (99.7)	1700°C	Crucible	ø 6.8 mm/85 µl	Only available with flat slip-on plate JA006844	GB399972
Pt/Rh (90/10)	1700°C	Crucible	ø 6.8 mm/85 µl	Only available with flat slip-on plate JA006844	NGB825767
Al ₂ O ₃ (99.7)	1700°C	Corrosive slip-on-plate		Set of 2 pieces, for ø 5.2 mm crucibles	J1670612
Al ₂ O ₃ (99.7)	1700°C	Large volume slip-on-plate		For sample position	JA004734
Al ₂ O ₃ (99.7)	1700°C			For reference position	JA004735
Al ₂ O ₃ (99.7)	1700°C	Crucible	ø 8.0 x 10.0 mm/400 µl	Only available for large slip-on plate JA004734	JA004738



Large crucible made of Al, order no. J1560180



Crucible and lid made of Al, order no. J1560179 and J1560184



Large Al_2O_3 crucible, order no. J1560182



Cap-type lids made of Al_2O_3 , order no. JA000981



Crucible made of Al_2O_3 , order no. J1560181



Crucible made of fused silica, order no. J5900881

Spare Parts for the STA 2500 *Regulus*

Spare parts	Remark	Order Number
Radiation shield	Standard version	JA003597
Radiation shield	Special version	JA004827
Sample carrier receiver		JA003596
TGA-DTA sample holder rod	Type P, 1100°C; set of 2 pieces	J1670610
TGA-DTA sample holder rod	Type S, 1600°C; set of 2 pieces	JA004768



Large crucible made of Pt, order no. J5900879



Reshaping tool for crucible made of Pt, order no. J7672306



Standard radiation shield, order no. JA003597



Special radiation shield, order no. JA004827



Slip-on plates for measurements in corrosive atmospheres, order no. JA004768



Sample carrier receiver, order no. JA003596



Slip-on plates made of Al_2O_3 , order no. JA003598



Slip-on plates made of Al_2O_3 for sample and reference position, order no. JA004734 and JA004735



Large crucible made of Al_2O_3 , order no. JA004738

Crucibles Made of Aluminum

Crucibles for the STA 449 **F1/F3 Jupiter**[®] and DSC 404 **F1/F3 Pegasus**[®]

What sets the STA 449 **F1/F3 Jupiter**[®] and DSC 404 **F1/F3 Pegasus**[®] systems apart is not only their flexibility in furnaces and sensors but also the huge variety of possible crucibles. For the broad temperature range from -150°C to 2400°C, the crucible materials vary from aluminum to magnesium oxide and tungsten to zirconium oxide.

Besides DSC and TGA (for STA) crucibles, plates and net-shaped plates

are also available in different materials and dimensions.

For inhomogeneous samples and those with an extremely low density, special TGA sample holders and large crucibles are available. The automatic sample changer (ASC) with its gripper and carousel allows for the use of nearly any crucible type including specialties such as low-, medium- and high-pressure crucibles.



**Crucibles Made of Aluminum for the STA 449 F1/F3/F5 Jupiter[®],
STA 449 F3 Nevio and DSC 404 F1/F3 Pegasus[®]**

Material (Purity/%)	Temperature Range	Consisting of	Dimension/ (ø x Height)/ Volume	Remarks	Order Number
Al (99.5)	Max. 600°C	Concavus pan* + lid	ø 5 mm/30/40 µl	Set of 96, 3in1 Box, cold weldable**	DSC21400A66.010.00
Al (99.5)	Max. 600°C	Concavus pan*	ø 5 mm/30/40 µl	3in1 Box, 96 pieces	NGB814672
Al (99.5)	Max. 600°C	Concavus pan	ø 5 mm/30/40 µl	Set of 100 pcs.	NGB817525
Al (99.5)	Max. 600°C	Concavus lid		Set of 100 pcs.	NGB817526
Al (99.5)	Max. 600°C	Crucible + lid	ø 6 mm/25/40 µl	Set of 100, cold weldable**	6.239.2-64.5.00
Al (99.5)	Max. 600°C	Crucible + lid	ø 6 mm/25/40 µl	Set of 500, cold weldable**	6.239.2-64.51.00
Al (99.5)	Max. 600°C	Crucible + punched lid (0.05 mm)	ø 6 mm/40 µl	Set of 100, cold weldable**	6.239.2-64.8.00
Al (99.5)	Max. 600°C	Crucible + punched lid (0.05 mm)	ø 6 mm/40 µl	Set of 500, cold weldable**	6.239.2-64.81.00
Al (99.5)	Max. 600°C	Crucible	ø 6.7 mm/85 µl	Set of 100 pieces, non-weldable	NGB810405
Al (99.5)	Max. 600°C	Lid		Set of 100 pieces, for NGB810405	NGB810406

* Using Concavus pans with ASC instrument which were delivered before 2014 may require re-adjustment of ASC gripper.

** Please note: One and the same sealing press is capable of sealing all the Al crucibles, order no. 6.240.10-80.0.00A, see optional toolkits, page 11



Concavus pans in the antistatic 3in1 Box

**Low-Pressure Crucibles Made of Aluminum for TGA-DSC Sensors of the STA 449 F1/F3/F5 Jupiter^{®1},
STA 449 F3 Nevio¹ and DSC Sensors of the DSC 404 F1/F3 Pegasus^{®2}**

Material (Purity)	Temperature Range	Consisting of	Dimension/ Volume	Remarks	Order Number
Al (99.5)	Max. 600°C	Crucible + Lid	ø 6 mm/40 µl; 3 bar	Set of 100 pieces, cold weldable	DSC21400A65.030-00
Al (99.5)	Max. 600°C	Crucible + Lid	ø 6 mm/40 µl; 3 bar	Set of 500 pieces, cold weldable	DSC21400A65.040-00
Al (99.5)	Max. 600°C	Crucible + Lid	ø 6 mm/100 µl; 3 bar	Set of 100 pieces, cold weldable	DSC21400A65.050-00
Al (99.5)	Max. 600°C	Crucible + Lid	ø 6 mm/100 µl; 3 bar	Set of 500 pieces, cold weldable	DSC21400A65.060-00
Al (99.5)	Max. 600°C	Crucible	ø 6 mm/40 µl; 3 bar	100 pieces	DSC21400A65.030-01
Al (99.5)	Max. 600°C	Crucible	ø 6 mm/100 µl; 3 bar	100 pieces	DSC21400A65.050-01
Al (99.5)	Max. 600°C	Lid	for crucibles of ø 6 mm	100 pieces	6.239.2-64.5.02

¹ STA 449 F1/F3 Jupiter[®] sensors: HTP40000AXX.000-00 (XX = 78, 77, 73, 74, 79 or 63), STA 449 F5 Jupiter[®] sensor HTP40000AXX.000-00 (XX=69, 73)

² DSC 404 F1/F3 Pegasus[®] sensors: DSC404F1AXX.000-00 (XX = 78, 77, 73, 74, 79 or 75)

DSC Crucibles for Measurements in a Pressure-Tight Environment, Large TGA Crucibles and Slip-On Plates

Medium- and High-Pressure Crucibles for TGA-DSC Sensors (HTP 4000A69/70/71/72.000-00) of the STA 449 **F1/F3/F5** Jupiter®, STA 449 **F3** Nevio and DSC sensors of the DSC 404 **F1/F3** Pegasus®

Material (Purity/%)	Temperature Range	Consisting of	Dimension/ (ø x Height)/ Volume	Remarks	Order Number
CrNi steel (AISI 304)	Max. 250°C	Crucible + lid + seal	120 µl; 20 bar	Set of 25 pieces, seal made of FPM	6.240.1-68.1.00
O-ring seal	Max. 230°C	O-ring	Max. 20 bar	Seal made of PCTFE	NGB801765
CrNi steel (AISI 316L)	Max. 500°C	Crucible + lid, hexagonal, gold-plated surface, reusable	ø 6 mm, 27 µl, max. 100 bar	1 crucible + 5 Au sealing disks (sealing press 6.239.2-92.4)	6.239.2-92.3.00
CrNi steel (AISI 316L)	Max. 500°C	Crucible + lid, hexagonal, gold-plated surface, reusable	ø 6 mm, 27 µl, max. 100 bar	10 crucible + 50 Au sealing disks (sealing press 6.239.2-92.4)	6.239.2-92.31.00
CrNi steel (AISI 316L)	Max. 500°C	Crucible + lid, hexagonal, reusable	ø 6 mm, 27 µl, max. 100 bar	1 crucible + 5 Au sealing disks (sealing press 6.239.2-92.4)	6.239.2-93.3.00
CrNi steel (AISI 316L)	Max. 500°C	Crucible + lid, hexagonal, reusable	ø 6 mm, 27 µl, max. 100 bar	10 crucible + 50 Au sealing disks (sealing press 6.239.2-92.4)	6.239.2-93.31.00
CrNi steel (AISI 316L)	Max. 500°C	Crucible + lid, hexagonal, reusable	ø 6mm, 100 µl, max. 100 bar	1 crucible + 5 Au sealing disks (sealing press 6.239.2-92.4)	6.239.2-93.4.00
CrNi steel (AISI 316L)	Max. 500°C	Crucible + lid, hexagonal, gold-plated surface, reusable	ø 6mm, 100 µl, max. 100 bar	1 crucible + 5 Au sealing disks (sealing press 6.239.2-92.4)	6.239.2-92.8.00
Titanium (Grade 4)	Max. 500°C	Crucible + lid, hexagonal, reusable	ø 6mm, 27 µl, max. 100 bar	1 crucible + 5 Au sealing disks (sealing press 6.239.2-92.4)	6.239.2-92.6.00
Titanium (Grade 4)	Max. 500°C	Crucible + lid, hexagonal, reusable	ø 6mm, 100 µl, max. 100 bar	1 crucible + 5 Au sealing disks (sealing press 6.239.2-92.4)	6.239.2-92.9.00
Au seals (Au585)	Max. 500°C	For all high-pressure autoclaves, alloy: Au 58.5%, Ag 26%, Cu 15.5%			6.240.1-91.1.00
Sealing press		For crucibles: 6.239.2-92.3.00, -92.31.00, -92.6.00, -92.8.00, -92.9.00, -93.3.00, -93.31.00, -93.4.00, -93.41.00			6.239.2-92.4.00



Sealing tool for the high-pressure crucibles, order no. 6.239.2-92.4.00



Medium-pressure crucible (right) and high-pressure crucible (left)

Crucibles for TGA Sample Carrier (HTP40000A58.000-00)
of the STA 449 F1/F3/F5 Jupiter®, STA 449 F3 Nevio

Material (Purity/%)	Temperature Range	Consisting of	Dimension/ (ø x Height)/ Volume	Remarks	Order Number
Al ₂ O ₃ (99.7)	Max. 1700°C	Slip-on plate, flat	ø 10 mm		GB343550
Al ₂ O ₃ (99.7)	Max. 1700°C	Slip-on plate	ø 17 mm		GB445240
Al ₂ O ₃ (99.7)	Max. 1700°C	Crucible	0.9 ml		GB445215
Al ₂ O ₃ (99.7)	Max. 1700°C	Lid		For GB445215	GB445216
Al ₂ O ₃ (99.7)	Max. 1750°C	Crucible	0.9 ml	Highly sintered	NGB820039
Al ₂ O ₃ (99.7)	Max. 1750°C	Lid		For NGB820039	NGB820040
Al ₂ O ₃ (99.7)	Max. 1700°C	Crucible	3.4 ml		GB445213
Al ₂ O ₃ (99.7)	Max. 1700°C	Lid		Lid without hole, for GB445213	GB445214
Al ₂ O ₃ (99.7)	Max. 1750°C	Crucible	3.4 ml	Highly sintered	NGB820041
Al ₂ O ₃ (99.7)	Max. 1750°C	Lid		Lid without hole, for NGB820041	NGB820042
Al ₂ O ₃ (99.7)	Max. 1700°C	Crucible	5.0 ml		NGB809163
Al ₂ O ₃ (99.7)	Max. 1700°C	Lid		Lid without hole, for NGB809163	NGB814785
Al ₂ O ₃ (99.7)	Max. 1750°C	Crucible	5.0 ml	Highly sintered	NGB820037
Al ₂ O ₃ (99.7)	Max. 1750°C	Lid		Lid without hole, for NGB820037	NGB820038
Al ₂ O ₃ (99.7)	Max. 1750°C	Crucible	10.0 ml	Crucible mass approx. 8 g	NGB820017
Al ₂ O ₃ (99.7)	Max. 1700°C	Crucible	For sample dimension: ø 15 mm; high 25 mm		NGB811934
Al ₂ O ₃ (99.7)	Max. 1700°C	Crucible	ø 18 mm; ø _{inner} 14.5 mm; total height 14.5 mm; filling height 3 mm; volume 0.53 ml	For glove box applications	NGB811194
Repository	Crucible repository with handling tool, for glove box crucible NGB811194				HTP40000 A91.000-00
Pt/Ir (90/10)	Max. 1600°C	Net-shaped slip-on plate	ø 17 mm (100 meshes/cm ²)		GB398029
Pt/Ir (90/10)	Max. 1600°C	Net-shaped slip-on plate	ø 17 mm (225 meshes/cm ²)		GB398030
Pt/Ir (90/10)	Max. 1600°C	Slip-on plate	ø 10 mm		GB348834
Pt/Ir (90/10)	Max. 1600°C	Slip-on plate	ø 17 mm		GB348835



Al₂O₃ crucibles with different volumes (0.9 ml, 3.4 ml, 5 ml)



Al₂O₃ slip-on plates (ø 10 mm, 17 mm)

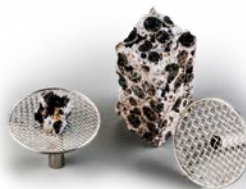

Pt/Ir net-shaped slip-on plates (ø 17 mm, 100/225 meshes/cm²)



Al₂O₃ crucible for glove box applications

Knudsen Cells (TGA), TGA and TGA-DTA Crucibles Through to the Highest Temperature Range



Crucible for TGA Sample Carrier (HTP40000A64.000-00/-010.00)

Material	Temperature Range	Sample Chamber Dimension	Remarks	Order Number
Fused Silica*	Max. 1100°C	3.4 ml	Only for TGA-sample carrier HTP40000A64.000-00	NGB811507

* Not available for STA 449 **F5 Jupiter**®

Crucibles for TGA Sample Carriers of the STA 449 **F1/F3 Jupiter**® with Turbo Pump – Knudsen Cells

Material	Temperature Range	Sample Chamber Dimension	Remarks	Order Number
ZrO ₂ ¹	Max. 2000°C	ø 12 mm x 3.7 mm high; orifice ø 2.896 mm (optically dimensioned)	Crucible + lid	6.226.1-69.5.00
Al ₂ O ₃ ² (99.7)	Max. 1700°C	ø 12 mm x 3.7 mm high; orifice ø 2.896 mm (optically dimensioned)	Crucible + lid	6.226.1-67.1.00
Al ₂ O ₃ ² (99.7)	Max. 1700°C	Outlet ø 0.3 mm (optically dimensioned)	Crucible + lid; also for carrier: 6.226.1-58.0.00+S	6.226.1-69.1.00
Al ₂ O ₃ ² (99.7)	Max. 1700°C	Outlet ø 0.1 mm (optically dimensioned)	Crucible + lid	6.226.1-69.2.00
Molybdenum ¹	Max. 2000°C	ø 12 mm x 3.7 mm high; orifice ø 2.896 mm (optically dimensioned)	Crucible + lid	6.226.1-69.4.00
MgO ²	Max. 1500°C	Outlet ø 0.3 mm (optically dimensioned)	Crucible + lid*	6.226.1-68.1.00

* depending on the atmosphere, the cell can potentially withstand 1650°C for short periods

¹ For sample carrier HTP40000A52.000-00

² For sample carrier HTP40000A58.000-00



Knudsen cells with different dimensions and orifice diameters

Crucibles for TGA Sample Carrier (HTP40000A52.000-00) of the STA 449 **F1/F3 Jupiter**®

Material	Temp. Range	Consisting of	Dimension/Volume	Order Number
Tungsten	Max. 2400°C	Crucible	0.3 ml	NGB809001
Graphite	Max. 2200°C	Crucible	0.3 ml	GB445333



Tungsten crucible (right)
and graphite crucible (left)

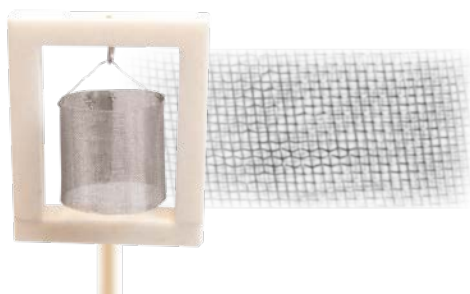

Crucibles for TGA Sample Carrier (HTP40000A60.000-00) for Hanging Samples of the STA 449 **F1/F3 Jupiter®** and STA 449 **F3 Nevio – Cage**

Material	Temp. Range	Consisting of	Dimensions	Order Number
Pt	Max. 1650°C	Cage, net-shaped	Cage ø 12 mm, height 12 mm, wire ø 0.04 mm, mesh width 0.12 mm	NGB813037
Pt	Max. 1650°C	Cage, net-shaped	Cage ø 12 mm, height 12 mm, wire ø 0.06 mm, mesh width 0.25 mm	NGB813036

Crucibles for DTA Sensor¹ of the DSC 404 **F1/F3 Pegasus®** and for TGA², TGA-DTA³ Sensor of the STA 449 **F1/F3/F5 Jupiter®**, STA 449 **F3 Nevio**

Material (Purity/%)	Temp. Range	Consisting of	Dimension/ Volume	Remarks	Order Number
Duran glass	Max. 600°C	Ampoule	Length after sealing ≈ 34 mm		GB461185
Fused silica	Max. 1000°C	Ampoule	Length after sealing ≈ 34 mm		GB461177
Al ₂ O ₃ (99.7)	Max. 1700°C	Slip-on plate	ø 10 mm		GB343550
Al ₂ O ₃	Max. 1700°C	Crucible	0.2 ml		GB445172
Al ₂ O ₃	Max. 1700°C	Crucible	0.3 ml	100 pieces	NGB810411
Al ₂ O ₃	Max. 1700°C	Lid		for NGB810411, GB445172; pierced, ø 0.5 mm hole	GB445175
Al ₂ O ₃	Max. 1750°C	Crucible	0.3 ml	100 pieces, highly sintered	NGB820035
Al ₂ O ₃	Max. 1750°C	Lid		for NGB820035, pierced	NGB820036
Al ₂ O ₃ (99.7)	Max. 1700°C	Crucible	0.3 ml; inner ø 6 mm	sixfold pierced	NGB813974
Al ₂ O ₃ (99.7)	Max. 1700°C	Crucible	0.9 ml		GB445215
Al ₂ O ₃ (99.7)	Max. 1700°C	Lid		for GB445215	GB445216
Pt	Max. 1600°C	Crucible	0.3 ml		NGB826144
Pt	Max. 1600°C	Lid for NGB826144			NGB826145
Graphite	Max. 2400°C	Crucible	0.3 ml	> 2200°C evaporation may occur ⁴	GB399222
Fine steel	Max. 600°C	Crucible	0.3 ml	Only in inert atmosphere	GB440112
Fine steel	Max. 600°C	Lid		for GB440112	GB440113

¹ DTA sample carrier of the DSC 404 **F1/F3 Pegasus®**: order no. DSC404F1AXX.000-00 (XX = 56, 57 or 68)

² TGA sample carrier of the STA 449 **F1/F3/F5 Jupiter®**: order no. HTP40000A58.000-00

³ TGA-DTA sample carrier of the STA 449 **F1/F3/F5 Jupiter®**: order no. HTP40000AXX.000-00 (XX = 56, 68, 51, 50 or 65)

⁴ Direct contact between crucible/sensor parts containing platinum should be avoided. >800°C, Al₂O₃ washer (NGB811071) must be used when crucible is placed on TGA-DSC sensor.



Ampoules for TGA and TGA-DTA measurements



TGA-DTA crucibles and slip-on plates

TGA-DTA, DSC and TGA-DSC Crucibles

Crucibles for TGA-DTA Sensor (HTP40000A53.000-00) of the STA 449 **F1/F3 Jupiter**[®] and DSC 404 **F1/F3 Pegasus**[®] (DSC404F1A53.000-00)

Material (Purity/%)	Temp. Range	Consisting of	Dimension/ Volume	Remarks	Order Number
Tungsten	Max. 2400°C	Crucible	80 µl	Wall thickness 0.3 mm, only for STA 449 F3 Jupiter [®]	GB453520
Tungsten	Max. 2400°C	Crucible	80 µl	Wall thickness 0.2 mm, BN liner available	NGB808999
Tungsten	Max. 2400°C	Lid		Pierced, for NGB808999	NGB809406
BN	Max. 1600°C	Liner	80 µl	For NGB808999	NGB805943
Glassy carbon	Max. 2000°C	Crucible	60 µl	Up to 500°C stable in oxidizing atmosphere	GB395116
Graphite	Max. 2400°C	Crucible	0.15 ml		GB427607
Graphite	Max. 2400°C	Lid		Pierced, for GB427607	NGB814940
Al ₂ O ₃	Max. 1700°C	Crucible	0.15 ml		GB399147
Al ₂ O ₃	Max. 1700°C	Lid		Pierced lid for GB399147	GB399973
ZrO ₂	Max. 2000°C	Crucible	0.15 ml		GB399148
Y ₂ O ₃	Max. 1700°C	Crucible	0.15 ml	Not useable in contact with alumina	NGB815846



TGA-DTA crucibles for highest temperatures

Crucibles for All DSC and TGA-DSC Sensors of the STA 449 **F1/F3/F5 Jupiter**[®], STA 449 **F3 Nevio** and DSC 404 **F1/F3 Pegasus**[®]

Material (Purity/%)	Temperature Range	Consisting of	Dimension/ Volume	Remarks	Order Number
PtRh/Al ₂ O ₃	Max. 1700°C	Crucible + liner + lid		For metal melts and other reactive materials	6.225.6-93.5.00
Al ₂ O ₃	Max. 1700°C	Crucible liner (spare for 6.225.6-93.5.00)			6.225.6-93.1.00
MgO	Max. 1500°C	Crucible liner (spare for NGB825767)		Minimum sale 10 pieces	NGB812638
BN ¹	Max. 1600°C	Crucible liner for NGB825767			NGB809833
Y ₂ O ₃ ²	Max. 1700°C	Crucible liner (spare for NGB825767)			NGB812634
Tool	Max. 1700°C			For reshaping of Pt crucibles	GB397964
Al ₂ O ₃ (99.7)	Max. 1700°C	Crucible	ø 6.8 mm/85 µl		GB399972
Al ₂ O ₃ (99.7)	Max. 1700°C	Lid		For GB399972	GB399973
Duran glass	Max. 600°C	Ampoule		Length after sealing ≈ 19 mm	6.240.1-93.2.00
Fused silica	Max. 1000°C	Ampoule		Length after sealing ≈ 19 mm	NGB815223



Crucibles for All DSC and TGA-DSC Sensors of the STA 449 **F1/F3/F5 Jupiter**[®],
STA 449 **F3 Nevio** and DSC 404 **F1/F3 Pegasus**[®] (Continuation)

Material (Purity/%)	Temperature Range	Consisting of	Dimension/ Volume	Remarks	Order Number
Fused silica	Max. 1000°C	Crucible	ø 6.7 mm/85 µl		GB399974
Fused silica	Max. 1000°C	Lid		For GB399974	GB399975
Pt/Rh (90/10)	Max. 1700°C	Crucible	ø 6.8 mm/85 µl		NGB825767
Pt/Rh (80/20)	Max. 1700°C	Crucible	ø 6.8 mm/0.19 ml	Height 6 mm	NGB801556
Pt/Rh (90/10)	Max. 1700°C	Lid		For NGB825767 and NGB801556	NGB825768
Al (99.5)	Max. 600°C	<i>Concavus pan</i> [*]	ø 5 mm/30/40 µl		NGB814672
Al (99.5)	Max. 600°C	Crucible	ø 6.7 mm/85 µl	Set of 100 pieces	NGB810405
Al (99.5)	Max. 600°C	Lid		For NGB810405	NGB810406
Gold (99.9)	Max. 900°C	Crucible + lid	ø 6.7 mm/85 µl		6.225.6-93.3.00
Ag	Max. 750°C	Crucible + lid	ø 6.7 mm/85 µl		6.225.6-93.4.00
ZrO ₂	Max. 2000°C	Crucible	85 µl	CaO-stabilized	GB397053
ZrO ₂	Max. 2000°C	Lid		For GB397053	GB397052
Graphite ³	Max. 2400°C	Crucible	85 µl	>2200°C evaporation may occur	GB399956
Graphite	Max. 2400°C	Lid		For GB399956	GB399957
Glassy carbon ³	Max. 2400°C	Crucible	ø 6 mm/50 µl		NGB811386
Glassy carbon ³	Max. 2400°C	Lid		For NGB811386	NGB812613
Al ₂ O ₃	Max. 1700°C	Washer	ø 6.8 mm, thick 0.2 mm	Inhibits sticking of Pt onto sensor type S and B	NGB811071
MgO	Max. 1500°C	Crucible	ø 6.7 mm, 85 µl		NGB812639
MgO	Max. 1500°C	Lid		For NGB812639	NGB812637
Y ₂ O ₃ ²	Max. 1700°C	Crucible	ø 6.7 mm, 85 µl		NGB812636
Y ₂ O ₃ ²	Max. 1700°C	Lid		For NGB812636	NGB812635
BN ¹	Max. 1600°C	Crucible	ø 6.7 mm, 85 µl	Inert gas required	NGB808836
BN ¹	Max. 1600°C	Lid		For NGB808836	NGB808835
Mo	Max. 2000°C	Crucible	ø 6.4 mm, 85 µl		NGB808165
Mo	Max. 2000°C	Lid		For NGB808165	NGB820241

¹ Maximum temperature when in contact with Pt, W and Rh or Pt/Rh alloys: 1600°C. For other materials getting in contact with BN, reactions have to be avoided which might damage crucible or liner. In the presence of He, Ar or vacuum, tungsten embrittles and hardens in contact with BN.

² May not be used with Al₂O₃, e.g., sensor plate, sapphire disc, etc.

³ Direct contact between the crucible and sensor parts containing platinum should be avoided. Above 800°C, a washer from Al₂O₃ (NGB811071) must be used for TGA-DSC sample carriers.

* Using *Concavus* pans with ASC instrument which were delivered before 2014 may require re-adjustment of the ASC gripper.



DSC and TGA-DSC crucible variety

Crucibles for Operation with the Automatic Sample Changer (ASC)

Crucibles for STA 449 F1/F3/F5 , STA 449 F3 Nevio and DSC 404 F1/F3 in ASC Operation				
Crucible Material (Purity/%), Volume Lid	ASC Gripper	TGA-DSC	TGA Sensor ²	Order Number
	STA 449 F1/F3 DSC 404 F1/F3	Sensor* DSC Sensor**	HTP40000A 67.000-00 HTP40000A 75.000-00	
Al (99.5), 30/40 µl (<i>Concavus</i> pan)	- ³	x	x	DSC21400A66.010-00 ⁴ DSC21400A66.020-00 ⁴ DSC21400A66.030-00 ⁴ DSC21400A66.040-00 ⁴ DSC21400A66.050-00 ⁴ NGB817525
Crucible with welded lid	- ³	x	x	
Al (99.5), 30/40µl, slide-in lid for <i>Concavus</i> pan	- ³	x	x	NGB815051
Al (99.5), 25/40 µl	- ¹	x	x	6.239.2-64.5.00
Crucible with welded lid	- ¹	x	x	
Al (99.5), 25/40 µl (500/pkg.)	- ¹	x	x	6.239.2-64.51.00
Crucible with welded lid	- ¹	x	x	
Al (99.5), 25/40 µl	- ¹	x	x	6.239.2-64.8.00
Crucible and lid with laser-cut-hole	- ¹	x	x	
Al (99.5), 25/40 µl (500/pkg.)	- ¹	x	x	6.239.2-64.81.00
Crucible and lid with laser-cut-hole	- ¹	x	x	
Al (99.5), low pressure, 40µl (100/pkg.)	- ¹	x	x	DSC21400A65.030-00
Al (99.5), low pressure, 40µl (500/pkg.)	- ¹	x	x	DSC21400A65.040-00
Crucible 40µl with welded lid	- ¹	x	x	
Al (99.5), low pressure, 100µl (100/pkg.)	- ¹	x	x	DSC21400A65.050-00
Al (99.5), low pressure, 100µl (500/pkg.)	- ¹	x	x	DSC21400A65.060-00
Crucible 100µl with welded lid	- ¹	x	x	
CrNi steel (AISI 302), medium-pressure, 120 µl	x	x	x	6.240.1-68.1.00
Crucible with lid	x	x	x	
Copper, 25 µl	-	x	x	6.239.2-64.6.00
CrNi steel (AISI 316L), high-pressure, 27 µl, gold-plated, 100 bar	x	x	Only for manual operation	6.239.2-92.3.00
CrNi steel (AISI 316L), high-pressure, 27 µl, 100 bar	x	x	Only for manual operation	6.239.2-93.3.00
CrNi (AISI 316L), high-pressure, 100 µl, gold-plated, 100 bar	x	x	Only for manual operation	6.239.2-92.8.00
CrNi (AISI 316L), high-pressure, 100 µl, 100 bar	x	x	Only for manual operation	6.239.2-93.4.00
Ti (Grade 4), high-pressure, 27 µl, 100 bar	x	x	Only for manual operation	6.239.2-92.6.00

Crucibles for STA 449 **F1/F3/F5**, STA 449 **F3** Nevio and DSC 404 **F1/F3** in ASC Operation

Crucible Material (Purity/%), Volume Lid	ASC Gripper		TGA Sensor ²	Order Number
	STA 449 F1/F3 DSC 404 F1/F3	TGA-DSC Sensor* DSC Sensor**	HTP40000A 67.000-00 HTP40000A 75.000-00	
Ti (Grade 4), high-pressure, 100 µl, 100 bar	x	x	Only for manual operation	6.239.2-92.9.00
Al ₂ O ₃ (99.7), ø 6.8 mm, 85 µl	x	x	x	GB399972
Crucible with lid (note: lid order no.)	x	x	x	GB399973
Fused silica, ø 6.8 mm, 85 µl	x	x	x	GB399974
Crucible with lid (note: lid order no.)	x	x	x	GB399975
Fused silica, ø 8 mm, 0.3 ml, open	x	-	x	NGB812506
Pt/Rh (90/10), ø 6.8 mm, 85 µl	x	x	x	NGB825767
Crucible with lid (note: lid order no.)	x	x	x	NGB825768
Pt/Rh (80/20), ø 6.8 x 6 mm, 190 µl	x	x	x	NGB801556
Crucible with lid (note: lid order no.)	x	x	x	NGB825768
Al (99.5), ø 6.7 mm, 85 µl	x	x	x	NGB810405
Crucible with lid (note: lid order no.)	x	x	x	NGB810406
Graphite ⁶ , ø 6.8mm, 85 µl	x	x	x	GB399956
Crucible with lid (note: lid order no.)	x	x	x	GB399957
Gold (99.9), ø 6.8 mm, 85 µl	x	x	x	6.225.6-93.3.00
Crucible with lid	x	x	x	
Silver, ø 6.8 mm, 85 µl	x	x	x	6.225.6-93.4.00
Crucible with lid	x	x	x	
ZrO ₂ , ø 6.8 mm, 85 µl	x	x	x	GB397053
Crucible with lid (note: lid order no.)	x	x	x	GB397052
Y ₂ O ₃ , ⁵ ø 6.8 mm, 85 µl	x	x	x	NGB812636
Crucible with lid ⁵ (note: lid order no.)	x	x	x	NGB812635
MgO, ø 6.8mm, 85 µl	x	x	x	NGB812639
Crucible with lid (note: lid order no.)	x	x	x	NGB812637
Al ₂ O ₃ (99.7), ø 8 x 8 mm, 300 µl	x	-	x	NGB803698
Crucible with lid (note: lid order no.)	x	-	x	NGB808209
Pt/Rh/Al ₂ O ₃ system with lid	x	x	x	6.225.6-93.5.00
Mo, ø 6.4 mm, 85 µl	x	x	-	NGB808165
Crucible with lid (note: lid order no.)	x	x	x	NGB820241
BN, ø 6.7 mm, 85 µl	x	x	only for manual operation	NGB808836
Crucible with lid (note: lid order no.)	-	x	-	NGB808835

¹ Special gripper for Al crucibles on request

² For the listed crucibles, the TGA-Sensor requires the slip-on plate made of Al₂O₃, order no. NGB809010

³ Using *Concavus* pans or 40µl low-pressure crucibles with ASC require re-adjustment of ASC gripper.

⁴ Please see crucible details on page 6

⁵ May not be used with Al₂O₃, e.g., sensor plate, sapphire disc, etc.

* TGA-DSC Sensor: HTP40000A**XX**.000-00 (**XX** = 63, 66, 73 or 74)

** DSC Sensor: DSC404F1A**XX**.000-00 (**XX** = 63, 66, 7

⁶ Direct contact between the crucible and sensor parts containing platinum should be avoided.
> 800°C, a washer from Al₂O₃ (NGB811071) must be used for TGA-DSC sample carriers.

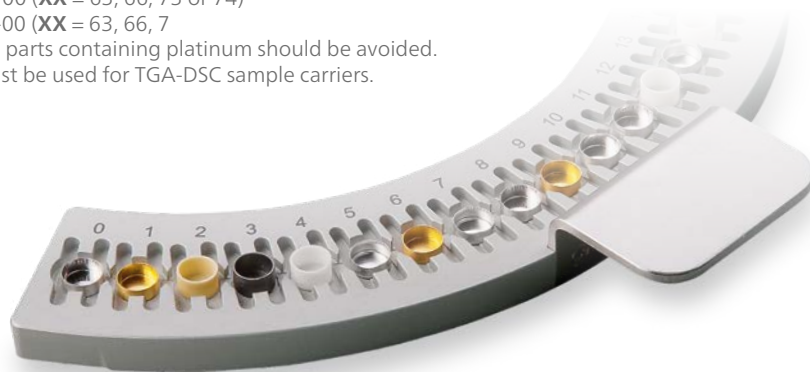

Sensors and Sample Carriers

DSC, TGA-DSC Sensors and TGA Sample Carriers

Nearly all DSC, TGA and STA instruments allow measurements with exchangeable DSC and DTA or TGA, TGA-DTA and TGA-DSC sensors and sample carriers which cover different temperature ranges.

Additionally, the instruments differ in the types of thermocouple which are compatible with them, as well as their ability to accommodate large crucibles. The type of thermocouple selected influences the sensitivity and resolution of a given DSC or STA system.

Choosing the right thermocouple can thus improve the measurement curve and also the evaluated test results, so this should be as carefully considered as the temperature range.

The following pages give an overview of the DTA, DSC, TGA, TGA-DSC and TGA-DTA sensors and sample carriers for these instruments:

- DSC 204 **F1 Phoenix**®
- DSC 404 **F1/F3 Pegasus**®
- STA 449 **F1/F3/F5 Jupiter**®
- TG 309 **Libra**® series
- TG 209 **F3 Tarsus**®
- TG 209 **F1 Libra**®



DSC 204 **F1** Phoenix[®] Sensors, TG 309 Libra[®], TG 209 **F1** Iris[®] /Libra[®], TG 209 **F3** Tarsus[®] and TG 209 **F1/F3** Nevio Sample Carriers



τ -sensor with low time constant and very good sensitivity for standard applications



μ -sensor with extremely high sensitivity

DSC 204 **F1** Phoenix[®]

Sensor Type*	Temperature Range	Remarks	Order Number
τ -sensor	-180°C to 700°C	Complete system, ready for installation → High-resolution sensor	6.240.10-09.0.00
μ -sensor	-150°C to 400°C	Complete system, ready for installation → High-sensitivity sensor	6.240.10-11.0.00

* From instrument series no. 240 10 034 on

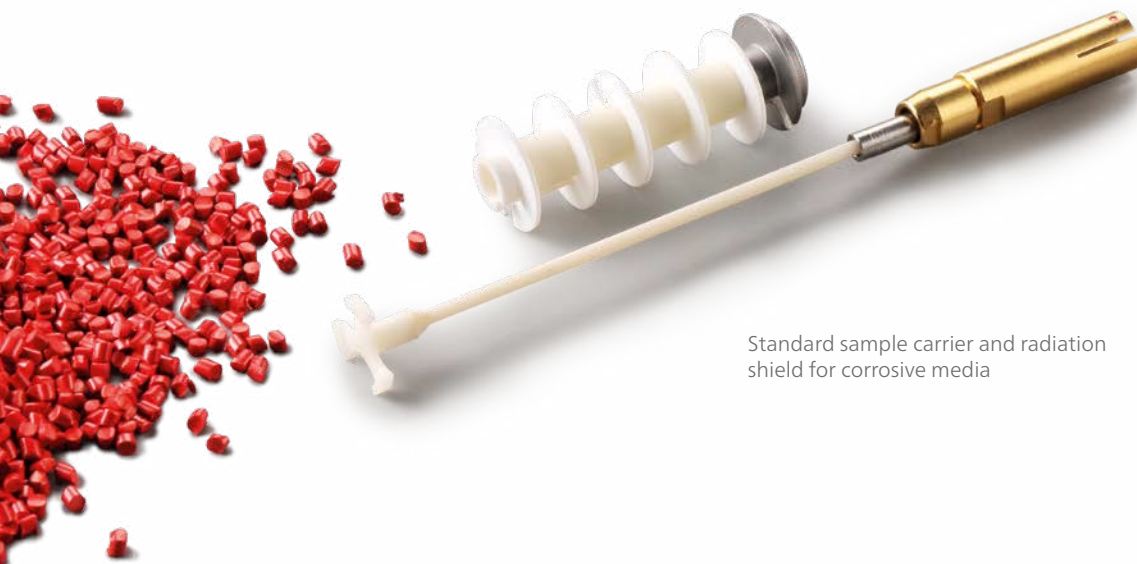

Standard sample carrier and radiation shield for corrosive media

TG 309 *Libra*® series, TG 209 **F1** *Libra*®** – All instruments,
 TG 209 **F1** *Iris*®*** – As of instrument No. 220 10 077*,
 TG 209 **F3** *Tarsus*®*** – As of instrument No. TGA209F3A-0010-L*

Sample Carrier Material	Temperature Sensor Type	Remarks	Radiation shield and crucible included	Order Number
Al ₂ O ₃	Type P	Higher sensitivity for <i>c-DTA</i> ®, with SiO ₂ coating, up to 7 mm crucible OD	X	TGA30900A60.000-00
Al ₂ O ₃	Type P	Higher sensitivity for <i>c-DTA</i> ®, with SiO ₂ coating, up to 7 mm crucible OD	-	TGA30900A60.010-00
Al ₂ O ₃	Type P	Higher sensitivity for <i>c-DTA</i> ®, with SiO ₂ coating, up to 9 mm crucible OD	X	TGA30900A61.000-00
Al ₂ O ₃	Type P	Higher sensitivity for <i>c-DTA</i> ®, with SiO ₂ coating, up to 9 mm crucible OD	-	TGA30900A61.010-00
Al ₂ O ₃	Type P	Sample support made of Al ₂ O ₃ , up to 7 mm crucible OD	X	TGA30900A62.000-00
Al ₂ O ₃	Type P	Sample support made of Al ₂ O ₃ , up to 9 mm crucible OD	-	TGA30900A62.010-00
Al ₂ O ₃	Type P	Sample support made of Al ₂ O ₃ ; up to 9 mm crucible OD	X	TGA30900A63.000-00
Al ₂ O ₃	Type P	Sample supports made of Al ₂ O ₃ , up to 9 mm crucible OD	-	TGA30900A63.010-00
Al ₂ O ₃	Type P	Sample support made of Al ₂ O ₃ , with protected thermocouple, particularly suitable for corrosive media, up to 7 mm crucible OD	X	TGA30900A65.000-00
Al ₂ O ₃	Type P	Sample support made of Al ₂ O ₃ , with protected thermocouple, particularly suitable for corrosive media, up to 7 mm crucible OD	-	TGA30900A65.010-00
Al ₂ O ₃	Type P	Sample support made of Al ₂ O ₃ , with protected thermocouple, particularly suitable for corrosive media, up to 9 mm crucible OD	X	TGA30900A66.000-00
Al ₂ O ₃	Type P	Sample support made of Al ₂ O ₃ , with protected thermocouple, particularly suitable for corrosive media, up to 9 mm crucible OD	-	TGA30900A66.010-00
Radiation shield		Made of Al ₂ O ₃ , for TG 309 <i>Libra</i> ®, TG 209 F1 <i>Libra</i> ® (all instruments); for TG 209 F1 <i>Iris</i> ® as of instrument No. 220 10 159; for TG 209 F3 <i>Tarsus</i> ® as of No. TGA209F3A-0049-L		6.220.10-60.3.00

* Please contact us for sample carriers for TG 209 **F1** *Iris*® up to instruments No. 220 10 076 and for sample carriers for TG 209 **F3** *Tarsus*® up to instrument No. TGA209F3A-0009-L.

** Sample carriers have been updated. New sample carriers are still suitable for TG 209 **F1** *Iris*®, TG 209 **F1** *Libra*®, TG 209 **F3** *Tarsus*® instruments

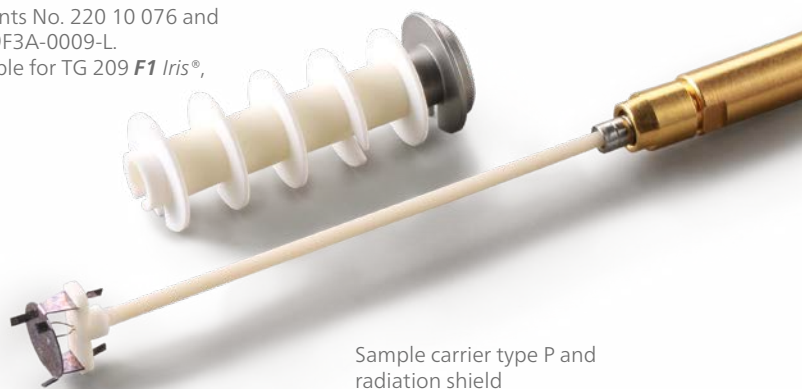

Sample carrier type P and radiation shield

Sensors and Sample Carriers

DTA and DSC Sensors

DTA Sensors for the DSC 404 F1/F3 Pegasus®				
Sensor Type	Temperature Range	Crucible/Volume/ Order Number	Radiation Shield	Order Number
Type S	25°C to 1650°C	2x Al ₂ O ₃ , 0.3 ml, NGB810411	Integrated	DSC404F1A56.000-00
Type S, protected thermocouples	25°C to 1650°C	2x Al ₂ O ₃ , 0.3 ml, NGB810411	Integrated	DSC404F1A68.000-00
Type B	25°C to 1750°C	2x Al ₂ O ₃ , 0.3 ml, NGB820035	Integrated	DSC404F1A57.000-00
W3%Re/W25%Re (exchangeable)	25°C to 2000°C	2x tungsten, GB453520	Integrated	DSC404F1A53.000-00

DSC Sensors for the DSC 404 F1/F3 Pegasus® – for Standard & c _p Measurements*				
Sensor Type	Temperature Range	Crucible/Volume/Order Number	Radiation Shield	Order Number
Type S	25°C to 1650°C	2x Al ₂ O ₃ crucible GB399972 and lid GB399973	Integrated	DSC404F1A69.000-00
Type S, octagonal design	25°C to 1650°C	2x PtRh crucible, NGB825767, lid NGB825768 2x Al ₂ O ₃ crucible, GB399972, lid GB399973	Integrated	DSC404F1A54.000-00
Type P	-150°C to 1000°C	2x Al ₂ O ₃ crucible, GB399972, lid GB399973	Integrated	DSC404F1A59.000-00
Type E	-150°C to 700°C, inert -150°C to 500°C, oxidizing	2x Al ₂ O ₃ crucible, GB399972, lid GB399973	Integrated	DSC404F1A70.000-00
Type K	-150°C to 800°C, inert -150°C to 500°C, oxidizing	2x Al ₂ O ₃ crucible, GB399972, lid GB399973	Integrated	DSC404F1A71.000-00
Type S	25°C to 1650°C	2x PtRh crucible, NGB825767, lid NGB825768 2x Al ₂ O ₃ crucible, GB399972, lid GB399973	Integrated	DSC404F1A72.000-00
Type B	25°C to 1750°C	2x PtRh crucible, NGB825767, lid NGB825768 2x Al ₂ O ₃ crucible, GB399972, lid GB399973	Integrated	DSC404F1A76.000-00
Type K, octagonal	-150°C to 800°C, inert -150°C to 500°C, oxidizing	2x Al ₂ O ₃ crucible, GB399972, lid GB399973	Integrated	DSC404F1A77.000-00
Type S, octagonal	25°C to 1650°C	2x PtRh crucible, NGB825767, lid NGB825768 2x Al ₂ O ₃ crucible, GB399972, lid GB399973	Integrated	DSC404F1A78.000-00
Type E, octagonal	-150°C to 700°C, inert -150°C to 500°C, oxidizing	2x Al ₂ O ₃ crucible, GB399972, lid GB399973	Integrated	DSC404F1A79.000-00

* c_p recommended up to 1400°C

DSC Sensors for the DSC 404 **F1/F3 Pegasus**® – for ASC Operation, Octagonal Design

Sensor Type	C _p	Temperature Range	Crucible/Volume/ Order Number	Radiation Shield	Order Number
Type S	Yes	25°C to 1650°C	2x PtRh crucible, NGB825767, lid NGB825768 2x Al ₂ O ₃ crucible, GB399972, lid GB399973	Integrated	DSC404F1A73.000-00
Type P	Yes	-150°C to 1000°C	2x PtRh crucible, NGB825767, lid NGB825768 2x Al ₂ O ₃ crucible, GB399972, lid GB399973	Integrated	DSC404F1A75.000-00
Type K	Yes	150°C to 800°C, inert -150°C to 500°C, oxidizing	2x Al ₂ O ₃ crucible, GB399972, lid GB399973	Integrated	DSC404F1A74.000-00
Type E	Yes	-150°C to 700°C, inert -150°C to 500°C, oxidizing	2x Al ₂ O ₃ crucible, GB399972, lid GB399973	Integrated	DSC404F1A66.000-00



DTA sensor with protected thermocouples



DSC sensor in round design with Pt crucibles



DSC sensor



DSC sensor in octagonal design for ASC operation

TGA Sample Carriers and TGA-DTA Sensors

TGA Sample Carriers for the STA 449 F1/F3 Jupiter® and STA 449 F3 Nevio – for Standard Measurements				
Material/ Sensor Type	Temperature Range	Crucible/Volume/Order Number	Radiation Shield	Order Number
Type P	-150°C to 1000°C	Al ₂ O ₃ , 3.4 ml, GB445213	Included	HTP40000A55.000-00
Type P	-150°C to 1000°C	-	Without	HTP40000A55.010-00
Type S	25°C to 1650°C	Al ₂ O ₃ , 3.4 ml, GB445213	Included	HTP40000A58.000-00
Type S	25°C to 1650°C	-	Without	HTP40000A58.010-00
Type B	25°C to 1750°C	Al ₂ O ₃ , 3.4 ml, NGB820041	Included	HTP40000B58.000-00
Type B	25°C to 1750°C	-	Without	HTP40000B58.010-00
Made of Al ₂ O ₃ , W3%Re/W25%Re	25°C to 1650°C	Al ₂ O ₃ , 3.4 ml, GB445213	Included	HTP40000A62.000-00
Made of Al ₂ O ₃ , W3%Re/W25%Re	25°C to 1650°C	-	Without	HTP40000A62.010-00
Made of fused silica, type S	25°C to 1100°C	Crucible required: Fused silica, 3.4 ml, NGB811507	Included	HTP40000A64.000-00
Made of fused silica, type S	25°C to 1100°C	-	Without	HTP40000A64.010-00
W3%Re/W25%Re	25°C to 2400°C	Tungsten, NGB809001	Included	HTP40000A52.000-00
W3%Re/W25%Re	25°C to 2400°C	-	Without	HTP40000A52.010-00
Radiation shield from tungsten	25°C to 2400°C	-	Complete	HTP40000A53.020-00

TGA type S sample carrier with different crucibles and plates, TGA type W sample carrier (W3%Re/W25%Re); for more crucibles and plates, see TGA crucibles table.



TGA Sample Carriers and TGA-DTA Sensors for the STA 449 *F1/F3 Jupiter*® and STA 449 *F3 Nevio* – with Special Design

Material/ Sensor Type	Temperature Range	Crucible Type	Radiation Shield	Order Number
TGA, type S, length 250 mm, for water vapor furnace HTP40000A88	25°C to 1650°C	Al ₂ O ₃ slip-on plate, ø 17 mm	Included	HTP40000A57.000-00
TGA, type S, length 250 mm, for water vapor furnace HTP40000A88	25°C to 1650°C	-	Without	HTP40000A57.010-00
TGA, made of Al ₂ O ₃ , type S, for hanging samples, sample size max. 13 x 20 mm	25°C to 1650°C	Options: net-shaped cage made of Pt, order no. NGB813036 or order no. NGB813037 (see page 24)	Included	HTP40000A60.000-00
TGA, made of Al ₂ O ₃ , type S, for hanging samples, sample size max. 13 x 20 mm	25°C to 1650°C		Without	HTP40000A60.010-00
TGA, made of Al ₂ O ₃ , type S, for measurements in an immersion bath (e.g., salt solution), for hanging samples	25°C to 1650°C	Special container made of Al ₂ O ₃ , 3 immersion container made of Pt and 5 immersion container made of BN	tube made of glass (single order no. NGB801706)	HTP40000B60.000-00
TGA-DTA, type S, hanging samples	25°C to 1650°C		Included	HTP40000A61.000-00
TGA-DTA, type S, hanging samples	25°C to 1650°C		Without	HTP40000A61.010-00



TGA-DTA sensor
for hanging samples



TGA sample carrier
for hanging samples



TGA sample carrier
for measurements in
an immersion bath

TGA-DTA and TGA-DSC Sensors

TGA-DTA Sensors for the STA 449 <i>F1/F3 Jupiter</i> ® – for Standard Measurements				
Sensor Type	Temperature Range	Crucible/Volume/Order Number	Radiation Shield	Order Number
Type E	-150°C to 700°C, inert -150°C to 500°C, oxidizing	2x Al ₂ O ₃ , 0.3 ml, NGB810411	Included	HTP40000A50.000-00
Type E	-150°C to 700°C, inert -150°C to 500°C, oxidizing	-	Without	HTP40000A50.010-00
Type K	-150°C to 700°C, inert -150°C to 500°C, oxidizing	2x Al ₂ O ₃ , 0.3 ml, NGB810411	Included	HTP40000A51.000-00
Type K	-150°C to 700°C, inert -150°C to 500°C, oxidizing	-	Without	HTP40000A51.010-00
Type P	-150°C to 1000°C	2x Al ₂ O ₃ , 0.3 ml, NGB810411	Included	HTP40000B56.000-00
Type P	-150°C to 1000°C	-	Without	HTP40000B56.010-00
Type P, protected thermocouples	-150°C to 1000°C	2x Al ₂ O ₃ , 0.3ml, NGB810411	Included	HTP40000B59.000-00
Type P, protected thermocouples	-150°C to 1000°C	-	Without	HTP40000B59.010-00
Type S	25°C to 1650°C	2x Al ₂ O ₃ , 0.3 ml, NGB810411	Included	HTP40000A56.000-00
Type S	25°C to 1650°C	-	Without	HTP40000A56.010-00
Type S, protected thermocouples	25°C to 1650°C	2x Al ₂ O ₃ , 0.3 ml, NGB810411	Included	HTP40000A68.000-00
Type S, protected thermocouples	25°C to 1650°C	-	Without	HTP40000A68.010-00
Type B	25°C to 1750°C	2x Al ₂ O ₃ , 0.3ml, NGB820035	Included	HTP40000B57.000-00
Type B	25°C to 1750°C	-	Without	HTP40000B57.010-00
Type D (W3%Re-W25%Re), protected thermocouples	25°C to 1500°C, not for oxidizing atmospheres!	2x Al ₂ O ₃ , 0.3 ml, NGB810411	Included	HTP40000A94.000-00
Type D (W3%Re-W25%Re), protected thermocouples	25°C to 1500°C, not for oxidizing atmospheres!	-	Without	HTP40000A94.010-00
Type D (W3%Re-W25%Re)	25°C to 1650°C, not for oxidizing atmospheres!	2x Al ₂ O ₃ , 0.3 ml, NGB810411	Included	HTP40000A65.000-00
Type D (W3%Re-W25%Re)	25°C to 1650°C, not for oxidizing atmospheres!	-	Without	HTP40000A65.010-00
W3%Re/W25%Re	25°C to 2400°C, not for oxidizing atmospheres!	2x tungsten, NGB808999, wall thickness 0.2 mm; optional for STA 449 <i>F3 Jupiter</i> ®: tungsten crucible, with wall thickness 0.3 mm, GB453520	Included	HTP40000A53.000-00
W3%Re/W25%Re	25°C to 2400°C, not for oxidizing atmospheres!	-	Without	HTP40000A53.010-00
Radiation shield from tungsten	25°C to 2400°C	-	Complete	HTP40000A53.020-00

TGA-DSC Sensors for the STA 449 F1/F3 Jupiter® –
for Standard Measurements

Sensor Type	Temperature Range	Crucible/Volume/Order Number	Radiation Shield	Order Number
Type K octagonal	-150°C to 800°C, inert -150°C to 500°C, oxidizing	2x Al ₂ O ₃ , 85 µl, crucible GB399972, lid GB399973	Included	HTP40000A77.000-00
Type K octagonal	-150°C to 800°C, inert -150°C to 500°C, oxidizing	-	Without	HTP40000A77.010-00
Type P	-150°C to 1000°C	2x Al ₂ O ₃ , 85 µl, crucible GB399972, lid GB399973	Included	HTP40000A59.000-00
Type P	-150°C to 1000°C	-	Without	HTP40000A59.010-00
Type S	25°C to 1650°C	2x Al ₂ O ₃ , 85 µl, crucible GB399972, lid GB399973	Included	HTP40000A69.000-00
Type S	25°C to 1650°C	-	Without	HTP40000A69.010-00
Type E	-150°C to 700°C, inert -150°C to 500°C, oxidizing	2x Al ₂ O ₃ , 85 µl, crucible GB399972, lid GB399973	Included	HTP40000A70.000-00
Type E	-150°C to 700°C, inert -150°C to 500°C, oxidizing	-	Without	HTP40000A70.010-00
Type E octagonal	-150°C to 700°C, inert -150°C to 500°C, oxidizing	2x Al ₂ O ₃ , 85 µl, crucible GB399972, lid GB399973	Included	HTP40000A79.000-00
Type E octagonal	-150°C to 700°C, inert -150°C to 500°C, oxidizing	-	Without	HTP40000A79.010-00
Type K	-150°C to 700°C, inert -150°C to 500°C, oxidizing	2x Al ₂ O ₃ , 85 µl, crucible GB399972, lid GB399973	Included	HTP40000A71.000-00
Type K	-150°C to 700°C, inert -150°C to 500°C, oxidizing	-	Without	HTP40000A71.010-00

Sensors and Sample Carriers



TGA-DTA sensors with different crucibles and plates; for more crucibles, please see TGA

TGA-DTA sensor Type W (W3%Re/W25%Re)

TGA-DTA sensor Type S, protected thermocouples

Different TGA-DSC Sensors

Radiation Shield for STA Systems

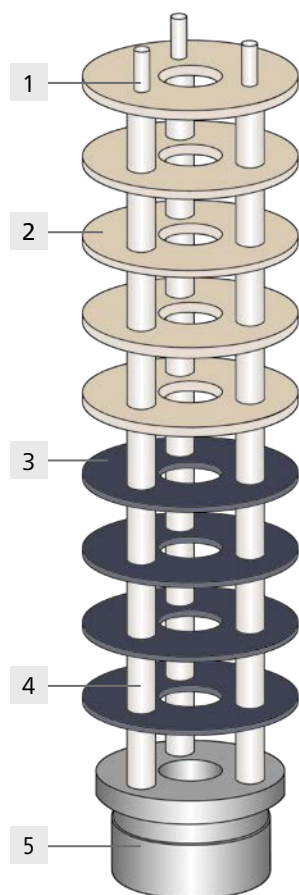

Radiation Shield with 3 Supporting Bars

Component parts

Radiation shield – Complete

- 1 Supporting bar made of Al_2O_3
- 2 Disk for radiation shield made of Al_2O_3
- 3 Disk for radiation shield made of nickel
- 4 Spacing tube made of Al_2O_3
- 5 Metal base for radiation shield

Order number

HTP40000A72.040-00

GB348216

NGB809780

NGB809779

GB351383

NGB809778

Radiation Shield for TGA Sample Carrier and TGA-DTA Sensor Type W (W3%Re/W25%Re)

Component parts

Radiation Shield
For TGA sample carrier
HTP40000A52.000-00
and TGA-DTA sensor
HTP40000A53.000-00

Order number

HTP4000A53.020-00

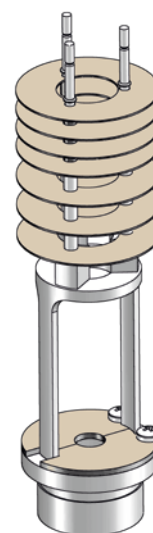

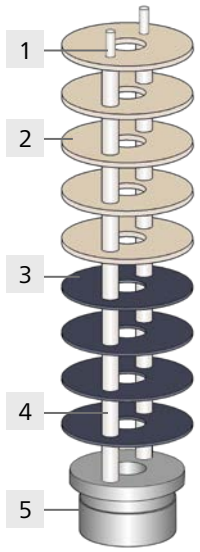

Component parts

- 1 Supporting bar made of Al₂O₃
- 2 Disk for radiation shield made of Al₂O₃
- 3 Disk for radiation shield made of nickel
- 4 Distance tube made of Al₂O₃
- 5 Metal base for radiation shield

Order number

- GB348216
- NGB806979
- NGB806987
- GB351383
- HTP40000A72.020-01



TGA and TGA-DSC Sensors for c_p Determination and Operation with the Automatic Sample Changer (ASC)

TGA-DSC Sensors for the STA 449 F1/F3/F5 Jupiter® and STA 449 F3 Nevio – for c_p Determination (Recommended up to 1400°C)				
Sensor Type	Temperature Range/ Atmosphere	Crucible/Volume/ Single Order Number	Radiation Shield	Order Number
Type S, round design, especially for c_p	25°C to 1650°C	2x PtRh crucible, NGB825767, lid NGB825768 2x Al ₂ O ₃ crucible, GB399972, lid GB399973	Included	HTP40000A54.000-00
Type S, round design, especially for c_p	25°C to 1650°C	-	Without	HTP40000A54.010-00
Type S	25°C to 1650°C	2x PtRh crucible, NGB825767, lid NGB825768 2x Al ₂ O ₃ crucible, GB399972, lid GB399973	Included	HTP40000A72.000-00
Type S	25°C to 1650°C	-	Without	HTP40000A72.010-00
Type S octagonal version	25°C to 1650°C	2x PtRh crucible, NGB825767, lid NGB825768 2x Al ₂ O ₃ crucible, GB399972, lid GB399973	Included	HTP40000A78.000-00
Type S octagonal version	25°C to 1650°C	2x PtRh crucible, NGB825767, lid NGB825768 2x Al ₂ O ₃ crucible, GB399972, lid GB399973	Without	HTP40000A78.010-00
Type B	25°C to 1750°C	2x PtRh crucible, NGB825767, lid NGB825768 2x Al ₂ O ₃ crucible, GB399972, lid GB399973	Included	HTP40000A76.000-00
Type B	25°C to 1750°C	-	Without	HTP40000A76.010-00



TGA, TGA-DTA and TGA-DSC Sensors for the STA 449 **F1/F3/F5 Jupiter®** and STA 449 **F3 Nevio** –
for Operation with the Automatic Sample Changer (ASC)

Sensor Type	Temperature Range/ Atmosphere	Crucible/Volume/ Single Order Number	Radiation Shield	Order Number
TGA-DSC, Type P	-150°C to 1000°C	2x PtRh crucible, NGB825767, lid NGB825768 2x Al ₂ O ₃ crucible, GB399972, lid GB399973	Included	HTP40000A63.000-00
TGA-DSC, Type P	-150°C to 1000°C	-	Without	HTP40000A63.010-00
TGA-DSC, Type E	-150°C to 700°C, inert 150°C to 500°C, oxidizing	2x Al ₂ O ₃ , 85 µl, crucible GB399972, lid GB399973	Included	HTP40000A66.000-00
TGA-DSC, Type E	-150°C to 700°C, inert -150°C to 500°C, oxidizing	-	Without	HTP40000A66.010-00
TGA-DSC, Type S, for c _p	25°C to 1650°C	2x PtRh crucible, NGB825767, lid NGB825768 2x Al ₂ O ₃ crucible, GB399972, lid GB399973	Included	HTP40000A73.000-00
TGA-DSC, Type S, for c _p	25°C to 1650°C	-	Without	HTP40000A73.010-00
TGA-DSC, Type K	-150°C to 700°C, inert -150°C to 500°C, oxidizing	2x Al ₂ O ₃ , 85 µl crucible GB399972, lid GB399973	Included	HTP40000A74.000-00
TGA-DSC, Type K	-150°C to 800°C, inert -150°C to 500°C, oxidizing	-	Without	HTP40000A74.010-00
TGA, type S	25°C to 1650°C	Spare part: slip-on plate made of Al ₂ O ₃ , NGB809010 Crucible: Al ₂ O ₃ , 85 µl, GB399972 Lid: GB399973	Included	HTP40000A75.000-00
TGA, type S	25°C to 1650°C	-	Without	HTP40000A75.010-00
TG-DTA, Type S, with protected thermocouples and slip-on plates	25°C to 1650°C	Spare part: slip-on plate made of Al ₂ O ₃ , NGB815222; 2x Al ₂ O ₃ crucible, GB399972, lid GB399973	Included	HTP40000B68.000-00
TG-DTA, Type S, with protected thermocouples and slip-on plates	25°C to 1650°C	Spare part: slip-on plate made of Al ₂ O ₃ , NGB805010	Without	HTP40000B68.010-00
TGA, type P	-150°C to 1000°C	Spare part: slip-on plate made of Al ₂ O ₃ , NGB809010 Crucible: Al ₂ O ₃ , 85 µl, GB399972	Included	HTP40000A67.000-00
TGA, type P	-150°C to 1000°C	-	Without	HTP40000A67.010-00
TGA-DSC, Type B	25°C to 1750°C	2xPtRh crucible, NGB825767, lid NGB825768 2x Al ₂ O ₃ crucible, GB399972, lid GB399973	Included	HTP40000B73.000-00
TGA-DSC, Type B	25°C to 1750°C	-	Without	HTP40000B73.010-00



TGA-DSC sensor for
ASC operation



TGA-DTA sample carrier (with
protected thermocouples) and
slip-on plates for ASC operation

Sensors and
Sample Carriers

Special Sample Carriers for Special Applications – OTS®

Oxygen Trap System – OTS®

The OTS® oxygen trap system, for the STA 449 **F1/F3 Jupiter®** and DSC 404 **F1/F3 Pegasus®** systems removes traces of residual oxygen in the gas atmosphere inside the instrument. A residual oxygen content of <1ppm can be achieved.

A ceramic substrate bearing a getter ring is mounted on the sample carrier or in the sample carrier tube.

This getter ring is capable of almost entirely eliminating the residual oxygen after evacuation.

Residual O₂ level is a function of:

- Vacuum tightness of the instrument
- Desorption of O₂ from the walls
- Vacuum tightness of the gas supply
- Purity of the purge gas

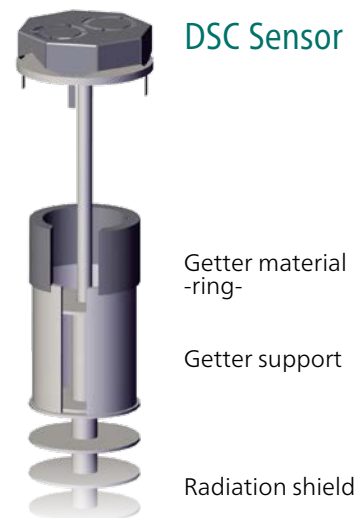

OTS® – for STA 449 **F1/F3/F5 Jupiter®**, STA 449 **F3 Nevio** and DSC 404 **F1/F3 Pegasus®**

Instrument	Order Number
STA – OTS® getter support and ring; incl. 3 rings	HTP40000A97.010-00
STA – OTS® getter support and ring; incl. 3 rings; shortened version for using with protected sample carrier HTP40000A68.000-00 DSC	HTP40000A97.020-00
DSC – OTS® getter support and ring; incl. 3 rings	HTP40000A98.010-00
STA/DSC – getter ring (for ordering separately)	NGB809270

Please note: The OTS® system can be used with all sensor types. Restrictions may occur with sensor type P when used with the steel and silver furnace. Please contact your sales & service representative for details.

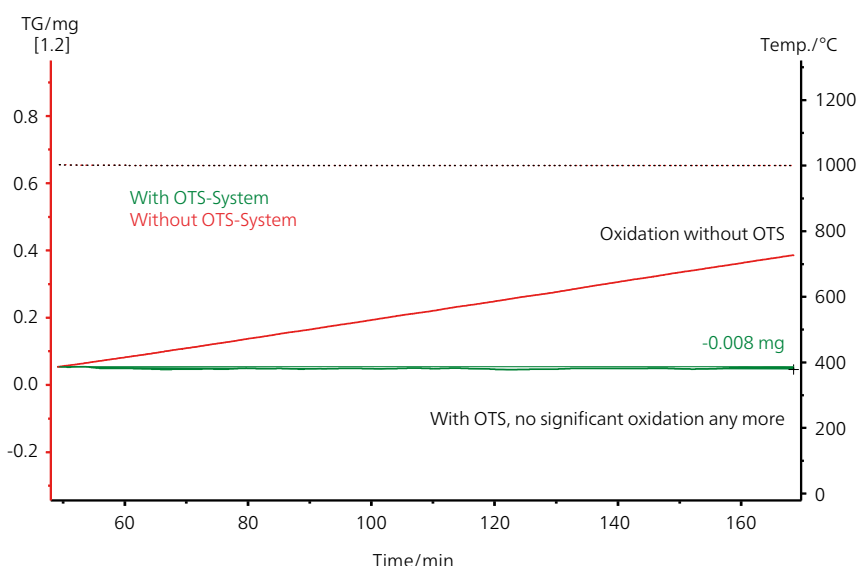

STA measurement of zirconium under isothermal conditions

Oxidation of Zirconium

In this example, a zirconium sample (190.0 mg) was measured with the STA 449 **F1 Jupiter®** in a helium atmosphere under isothermal conditions (1000°C). After three hours, oxidation of the Zr sample (red curve) led to a total mass increase of approx. 0.38 mg when no OTS® was used. When the OTS® system was applied to the sample carrier for a measurement on the same sample mass, however, no significant oxidation occurred (green curve). The mass increase was determined to amount to only 0.008 mg.

Special Sample Carriers for Special Applications – Hanging Samples

Large Sample Surface – Excellent Atmospheric Access

The special TGA sample carrier and TGADTA sensor for hanging or suspended samples allow perfect access to all sample surfaces by the atmosphere.

These Al_2O_3 sample carriers and sensors with Al_2O_3 frame are available for the STA 449 **F1/F3/F5 Jupiter**® systems (TGA order no. HTP40000A60.000-00; TGA-DTA order no. HTP40000A61.000-00).

The sample carrier is easy to handle and allows selection of the hanging wires according to the sample properties.

Advantages of the Sample Carrier for Hanging Samples

- Sample can be hung down directly
- Bendable thermocouple type S
- Improved contact between the sample and purge gas
- Sample dimensions up to 13 x 20 mm
- Very slow mass increase detectable ($\mu\text{g}/\text{hour}$ range)
- Long-term signal stability, typical drift less than $0.1\mu\text{g}/\text{h}$
- Choice of atmosphere:
 - O_2
 - Corrosive
 - Controlled humidity



TGA-DTA sensor for hanging samples

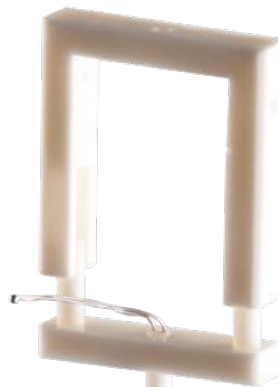

TGA sample carrier



TGA-DTA sample carrier

Calibration

Calibration is a fundamental requirement for thermoanalytical investigations. The knowledge of a quantitatively defined relationship between the value indicated by the measuring instrument and the correct value is essential.

Calibration of modern Differential Scanning Calorimeters (DSC) and Simultaneous Thermal Analyzers (STA) is achieved by quantification of the produced signal when a known quantity of energy is generated within the system. The calibration procedure consists of measuring thermal properties of standard materials which are well known.

Experimental conditions of calibration and measurement should be matched as closely as possible: not only the quantity of energy to be measured must be similar but the site and kinetics of the generation and temperature range should be as close as possible in both calibration and measurement experiments. All the results of subsequent measurements depend on the validity of the calibration. Therefore, it is mandatory to carefully carry out all calibration procedures.

Crucible Selection

DSC and STA (TGA-DSC/DTA) measurements are strongly influenced by the crucible material.

The measurements shown here on indium in Al, Pt, stainless steel and Al_2O_3 crucibles clearly demonstrate that both the thermal conductivity and the mass of the crucible have an effect on the DSC and DTA peak shape.

The calibration procedures take these effects into consideration and eliminate the influence of the crucible material on the measurement results.

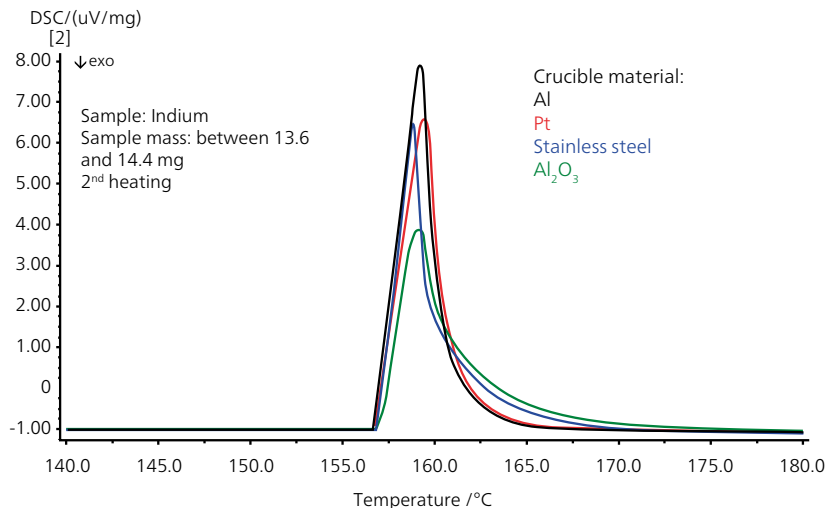

Indium measurements in different crucible materials

Calibration Materials and Kits

Reference materials must be homogeneous and stable, and the certified values must be accurate. Finding a material that can be used as a reference for more than one property is one of the goals of current research.

Various calibration kits and individual standards are available for each thermoanalytical method presented (DSC, TGA and STA) allowing the instrument to be calibrated across its entire temperature range and allowing for the use of different crucible types. The table gives an overview of possible combinations of calibration and crucible materials.

Calibration Materials										
Common Calibration Materials/Phase Transition Temperature		Crucible Materials								
		Al ₂ O ₃	C	SiO ₂	Al	Ag	Au	Stainless Steel	Pt	W
C10H16	-64.5°C	✓	✓	✓	✓	✓	✓	✓	✓	✓
H ₂ O	0.0°C	-	-	✓	✓	✓	✓	✓	✓	-
Biphenyl	69.2°C	✓			✓				✓	
RbNO ₃	164.2°C	!			✓	✓	✓		✓	
Benzoic acid	122.4°C	✓			✓				✓	
In	156.6°C	✓	✓	✓	✓	-	!	✓	!	
Sn	231.9°C	✓	✓	✓	✓	-	-	!	-	
Bi	271.4°C	✓			✓	-	-	✓	-	
KClO ₄	300.8°C	✓			✓	✓	✓		✓	
Pb	327.5°C	✓	✓	✓	✓	-	-	✓	-	!
Zn	419.5°C	✓	✓	✓	✓*	-	-	-	-	✓
Ag ₂ SO ₄	426.4°C	✓			✓			-	✓	
CsCl	476.0°C	✓			✓	✓	✓	✓	✓	
Li ₂ SO ₄	578.0°C	✓	✓	✓	✓		✓		✓	
Al	660.3°C	✓	✓	!	-	-	-	-	-	✓
BaCO ₃	808.0°C	✓		-	-	-		-	✓	
Ag	961.8°C	✓	✓	✓	-	-	-	-	-	✓
Au	1064.2°C	✓	-	✓	-	-	-	-	-	✓
Ni	1455.0°C	!	-	-	-	-	-	-	-	

- ✓ No solubility or effects on the melting temperature expected
- ! Corrosion reactions possible with negligible changes in the melting temperature
- Melt or transformation product reacts with the crucible material. Changes in the melting temperature can be expected.
- Compatibility unknown
- * Special preparation of the crucible necessary

Calibration Kits for DSC and DTA

Various calibration kits for different temperature ranges, methods, and crucible materials are available. The following tables show the common calibration kits for DSC and DTA measurements with their order numbers, materials transition temperatures (e.g., melting point), lid perforation, and compatibility with crucible material. These kits are used for temperature and enthalpy calibration.

Mass calibration of the TGA systems can usually be done automatically with an internal weight. For temperature calibration via the *c-DTA*® feature, the DSC/DTA calibration kits can be used.

Reference Materials for the STA 2500 <i>Regulus</i>					
Transition (°C)	Material			Quantity	Single Order No.
156.6	Indium	In	Granules	5 g	J1560142
231.9	Tin	Sn	Granules	5 g	J1560143
660.3	Aluminum	Al	Wire	0.1 g	J1560296
1064.2	Gold	Au	Wire	2.5 cm	J1560209
2072	Alumina	Al ₂ O ₃	Powder	50 cc	J1560146

DSC Sets for C _p , Sensitivity and Enthalpy Calibration				
Material	Disc ø	Thickness	For crucible type	Order No.
Sapphire	6 mm	Set of 0.25, 0.5, 0.75 and 1.0 mm	Metallic	6.235.1-91.1.00
Sapphire	6 mm	0.25 mm	Metallic	GB398543
Sapphire	6 mm	0.5 mm	Metallic	GB398454
Sapphire	6 mm	0.75 mm	Metallic	GB398455
Sapphire	6 mm	1.0 mm	Metallic	GB398456
Sapphire	5.2 mm	Set of 0.25, 0.5, 0.75 and 1.0 mm	Al ₂ O ₃	6.235.1-91.2.00
Sapphire	5.2 mm	0.25 mm	Al ₂ O ₃	GB397592
Sapphire	5.2 mm	0.5 mm	Al ₂ O ₃	GB397593
Sapphire	5.2 mm	0.75 mm	Al ₂ O ₃	GB397594
Sapphire	5.2 mm	1.0 mm	Al ₂ O ₃	GB397595
Sapphire	4 mm	Set of 0.25, 0.5, 0.75 and 1.0 mm	Cold-weldable Al crucibles	6.239.2-91.5.00
Sapphire	4 mm	0.25 mm	Cold-weldable Al crucibles	GB397973
Sapphire	4 mm	0.5 mm	Cold-weldable Al crucibles	GB397974
Sapphire	4 mm	0.75 mm	Cold-weldable Al crucibles	GB397975
Sapphire	4 mm	1.0 mm	Cold-weldable Al crucibles	GB397976

DSC/DTA Set* for the Use in Al ₂ O ₃ Crucibles Individual Substances in Glass Vials Order No.: 6.223.5-91.3.30				
Transition (°C)	Material		Quantity	Single Order No.
156.6	Indium	In	400 mg	6.223.5-91.3.01
231.9	Tin	Sn	400 mg	6.223.5-91.3.02
271.4	Bismuth	Bi	400 mg	6.223.5-91.3.11
419.5	Zinc	Zn	400 mg	6.223.5-91.3.03
660.3	Aluminum wire	Al	400 mg	6.223.5-91.3.05
961.8	Silver wire	Ag	400 mg	6.223.5-91.3.06
1064.2	Gold wire	Au	400 mg	6.223.5-91.3.07
1455.0	Nickel wire	Ni	400 mg	6.223.5-91.3.08

* Standard set can be used with high-pressure DSC

DSC Standard Set* – Substances in Sealed Al Crucibles Order No.: 6.239.2-91.3.30
(Volume 25 µl, sample mass minimum 10 mg) For HP-DSC also

Transition (°C)	Material		Pierced lid	Single Order No.
-64.5	Adamantane**	C ₁₀ H ₁₆		n/a
156.6	Indium	In	x	n/a
231.9	Tin	Sn	x	n/a
271.4	Bismuth	Bi	x	n/a
419.5	Zinc	Zn	x	n/a
476.0	Cesium chloride	CsCl	x	n/a

* Standard set can be used with high-pressure DSC

** HP-DSC: only atmospheric pressure

DSC Standard Set* – Substances in Sealed Al Concavus Crucibles Made of Al
(sample mass approx. 10 mg) Order No.: DSC21400B00.913-30

Transition (°C)	Material		Pierced lid	Single Order No.
-64.5	Adamantane**	C ₁₀ H ₁₆		n/a
156.6	Indium	In	x	n/a
231.9	Tin	Sn	x	n/a
271.4	Bismuth	Bi	x	n/a
419.5	Zinc	Zn	x	n/a
476.0	Cesium chloride	CsCl	x	n/a

* Standard set can be used with high-pressure DSC

** HP-DSC: only atmospheric pressure

DSC Low Pressure Set – Substances in Al Low-Pressure Crucibles Order No.: DSC21400A00.917-30 (40µl),
DSC21400A00.918-30 (100µl) (Volume 40µl/100µl, max. 3 bar, sample mass minimum 10 mg)

Transition (°C)	Material		Pierced lid	Single Order No.
-64.5	Adamantane	C ₁₀ H ₁₆		n/a
156.6	Indium	In	x	n/a
231.9	Tin	Sn	x	n/a
271.4	Bismuth	Bi	x	n/a
419.5	Zinc	Zn	x	n/a
476.0	Cesium chloride	CsCl	x	n/a

DSC High-Pressure Set – Substances in CrNi Steel Crucibles Order No.: 6.240.1-91.4.30
(Volume 27 µl, max. 100 bar, sample mass minimum 10 mg)

Transition (°C)	Material		Pierced lid	Single Order No.
-64.5	Adamantane	C ₁₀ H ₁₆		n/a
156.6	Indium	In		n/a
231.9	Tin	Sn		n/a
271.4	Bismuth	Bi		n/a
476.0	Cesium chloride	CsCl		n/a

DSC High-Pressure Set – Substances in CrNi Steel Crucibles Order No.: 6.240.1-91.5.30
(Volume 100 µl, sample mass minimum 10 mg)

Transition (°C)	Material		Pierced lid	Single Order No.
-64.5	Adamantane	C ₁₀ H ₁₆		n/a
156.6	Indium	In		n/a
231.9	Tin	Sn		n/a
271.4	Bismuth	Bi		n/a
476.0	Cesium chloride	CsCl		n/a

DSC Medium-Pressure Set – Substances in CrNi Steel Crucibles Order No.: 6.240.1-91.6.00
(Volume 120 µl, max. 20 bar, sample mass minimum 10 mg)

Transition (°C)	Material		Pierced lid	Single Order No.
-64.5	Adamantane	C ₁₀ H ₁₆		n/a
0.0	Water	H ₂ O		n/a
156.6	Indium	In		n/a
231.9	Tin	Sn		n/a

DSC µ-Sensor Set* – Substances in Al Crucibles (volume 25 µl) Order No.: 6.240.3-91.3.30

DSC µ-Sensor Set* – Substances in Al Concavus crucibles Order No.: DSC204F1A00.913-30

Transition (°C)	Material		Pierced lid	Single Order No.
-64.5	Adamantane	C ₁₀ H ₁₆		n/a
156.6	Indium	In	x	n/a
231.9	Tin	Sn	x	n/a
271.4	Bismuth	Bi	x	n/a

* Calibration set only for DSC **F1** with µ-sensor

DSC/DTA Set for the Use in Al₂O₃ Crucibles, Individual Substances in Glass Vials Order No.: 6.223.5-91.1.30

Transition (°C)	Material		Quantity	Single Order No.
-64.5	Adamantane (Powder)	C ₁₀ H ₁₆	400 mg	6.217.1-92.1.09
156.6	Indium	In	400 mg	6.223.5-91.3.01
231.9	Tin	Sn	400 mg	6.223.5-91.3.02
271.4	Bismuth	Bi	400 mg	6.223.5-91.3.11
419.5	Zinc	Zn	400 mg	6.223.5-91.3.03
476.0	Cesium chloride	CsCl	400 mg (for individual order, vial contains 500 mg)	6.223.5-91.2.05
660.3	Al wire	Al	400 mg	6.223.5-91.3.05

DSC/DTA Individual Substances in Glass Vials for Use in Pt Crucibles

Transition (°C)	Material		Quantity	Single Order No.
69.2	Biphenyl*	C ₁₂ H ₁₀	500 mg	6.223.5-91.2.01
122.4	Benzoic acid	C ₆ H ₅ COOH	500 mg	6.223.5-91.2.02
300.8	Potassium perchlorate*	KClO ₄	500 mg	6.223.5-91.2.04
426.2	Silver sulfate	AgSO ₄	500 mg	6.223.5-91.2.08
476.0	Cesium chloride	CsCl	500 mg	6.223.5-91.2.05
808.0	Barium carbonate	Ba CO ₃	500 mg	6.223.5-91.2.07

* Hazardous material

Please note that, due to very high cargo surcharges, we do not offer hazardous calibration materials together with the instrument. These reference materials will be offered separately.

Calibration Kits for TGA and STA

Temperature Calibration via Magnetic Transitions

TG 209 F1 <i>Libra</i> ®, TG 209 F3 <i>Tarsus</i>	Order Number
5 Curie Standards	6.221.2-91.3.00
Calibration supplement for magnetic transition (magnets)	
TG 209 F1 <i>Libra</i> ®	TGA209F1E93.100-00
TG 209 F3 <i>Tarsus</i>	TGA209F3A96.030-00
TG 309 <i>Libra</i> ® (except ASC 204 samples)	TGA30900A93.020-00
TG 309 <i>Libra</i> ® (for ASC 204 samples)	TGA30900A93.010-00

STA 449 F1/F3 <i>Jupiter</i> ®	Order Number
5 Curie Standards	6.221.2-91.3.00
Calibration supplement for magnetic transition (magnets)	HTP40000A96.030-00

Verification of Mass Changes for STA 449 **F1/F3/F5** *Jupiter*® and TG 309 *Libra*®, TG 209 **F1** *Libra*®/**F3** *Tarsus*® - Substance in Glass Vial

Material		Quantity	Single Order No.
Calcium oxalate monohydrate	C ₂ H ₂ CaO ₅	2 g	6.223.5-91.2.10

c-DTA® Set (TGA) for the Use in Al₂O₃ Crucibles, Substances in Glass Vials **Order No.: 6.221.5-91.1.30**

Transition (°C)	Material		Quantity	Single Order No.
156.6	Indium	In	400 mg	6.223.5-91.3.01
231.9	Tin	Sn	400 mg	6.223.5-91.3.02
271.4	Bismuth	Bi	400 mg	6.223.5-91.3.11
419.5	Zinc	Zn	400 mg	6.223.5-91.3.03
660.3	Aluminum wire (ø 1 mm)	Al	400 mg	6.223.5-91.3.05
961.8	Silver wire (ø 0.5 mm)	Ag	400 mg	6.223.5-91.3.06

c-DTA® Set* (TGA) for the Use in Al₂O₃ Crucibles, Substances in Glass Vials
Order No.: TGA209F1D91.010-30

Transition (°C)	Material		Quantity	Single Order No.
156.6	Indium	In	400 mg	6.223.5-91.3.01
231.9	Tin	Sn	400 mg	6.223.5-91.3.02
271.4	Bismuth	Bi	400 mg	6.223.5-91.3.11
419.5	Zinc	Zn	400 mg	6.223.5-91.3.03
660.3	Aluminum wire (ø 1 mm)	Al	400 mg	6.223.5-91.3.05
961.8	Silver wire (ø 0.5 mm)	Ag	400 mg	6.223.5-91.3.06
1064.2	Gold (ø 1.0 mm)	Au	400 mg	6.223.5-91.3.07

* This calibration set is recommended for the TG 309 *Libra*®, TG 209 **F1** *Libra*®

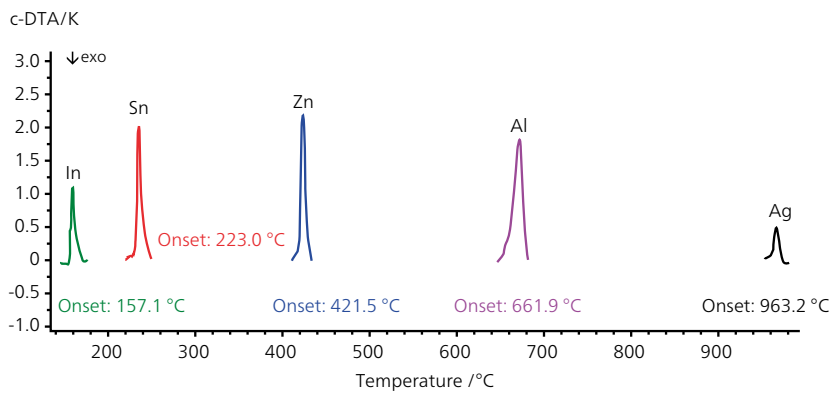

There are various reference materials which can be used for c-DTA® calibration routines.

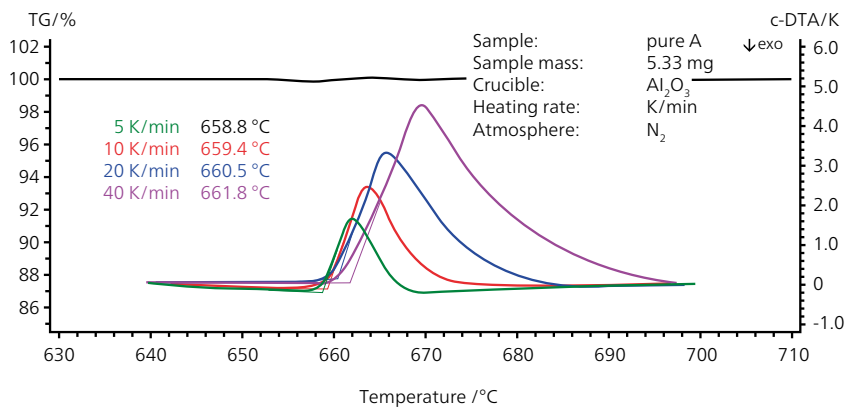

c-DTA® calibration in the TG 209 **F1** and **F3** systems. Excellent coupling of the Platinel sensor with the crucible guarantees that the influence of the heating rate will be small.

Chemical Behavior of Pt, Al₂O₃ and Graphite Crucibles and Sensors

Environmental Effects: Chemical Behavior of Crucibles and Sensors Made of Pt, Al₂O₃ and C

In practice, the service life of sensors (thermocouples) and crucibles is most heavily impacted by interactions with the environment. Diffused impurities, released from the samples, change the thermal tension or may even cause initial cracking of the thermocouple wire and crucible wall. The following tables give some details on the chemical compatibility of Pt, Al₂O₃ and C thermocouples and crucibles with other sample materials and gas atmospheres. The following lists also serve to illustrate how important regular inspections and calibration measurements are.

These overviews are not exhaustive, but meant rather as a guideline for the user. The temperatures given are primarily literature values. Temperatures under test conditions might shift to lower values. It is always advisable to run preliminary tests in separate furnaces.

Chemical Behavior of Platinum (Pt)

Critical	No resistance	Limited resistance
<ul style="list-style-type: none"> ▪ Halogens (Cl₂, F₂, Br₂), aqua regia ▪ Li₂CO₃, prior to emission of CO₂ (decomposition) ▪ PbO, FeCl₂ ▪ Be alloys (evaporation) ▪ HCl with oxidants (e.g., chromic acid, manganates, iron (III) and molten salts); reducing atmospheres ▪ Metals and metal vapors (e.g., B, Pb, Zn, Sn, Ag, Au, Li, Na, K, Sb, Bi, Ni, Fe, etc.; m Se > 320°C (evaporation)) ▪ Metals and metal oxides with reducing substances such as C, organic compounds or H₂ ▪ Oxides in an inert gas atmosphere at higher temperatures (reduction) ▪ Sulfur (roughening of the surface, embrittlement) ▪ Alkali hydroxides, -carbonates, -sulfates, -cyanides and rhodanides at higher temperatures ▪ KHSO₄ at higher temperatures ▪ Carbon black or free carbon >1000°C ▪ SiO₂ under reducing conditions ▪ SiC and Si₃N₄ >1000°C (release of elementary Si) ▪ HBr, KCl solution at high temperatures 	<ul style="list-style-type: none"> ▪ Mixtures of KNO₃ and NaOH at 700°C under exclusion of air ▪ Mixtures of KOH and K₂S at 700°C under exclusion of air ▪ LiCl at 600°C; MgCl₂, Ba(NO₃)₂ at 700°C ▪ HBr, HI, H₂O₂ (30%); HNO₃ at 100°C ▪ KCl decomposition products which form during melting at 768°C 	<ul style="list-style-type: none"> ▪ KHF₂, LiF₂, NaCl at 900°C ▪ Mixtures of NaOH and NaNO₃ at 700°C under exclusion of air



DSC sample carrier type S (Pt-Pt10%Rh)

Calibration

Chemical Behavior

Chemical Behavior of Alumina (Al₂O₃)

Critical

- N₂ in the presence of carbon (formation of AlN; not recommended to measure carbon black in N₂ atmosphere at elevated temperatures)
- F₂: formation of AlF₃ and O₂
- Cl₂: formation of AlCl₃ at >700°C
- Sulfur: no reaction with liquid sulfur; formation of sulfides occur in the presence of carbon in the gas phase
- H₂S: when heated, formation of Al₂S₃
- C: formation of carbides and Al above 1400°C
- HF: reaction to AlF₃ and H₂O at higher temperatures
- CuSO₄: above 1000°C, diffusion through the bottom of the crucible
- Compounds containing Si, e.g., MoSi₂; contamination of Al₂O₃ > 1200°C
- Metal fluorides: formation of [AlF₆]³⁻ anions and salts similar to cryolites
- SiO₂ glass: melt dissolves Al₂O₃
- Hydrogen sulfates of alkaline metals and alkaline-earth metals
- HCl: above 600°C, reactions in the presence of carbon
- B₂O₃ (Borax): melt dissolves Al₂O₃; formation of Al-borates and -borides
- Alkaline and alkaline-earth oxides and their salts with volatile anions; important for hydroxides, nitrides, nitrates, carbonates, peroxides, etc.
- CaC₂: when heated, formation of Al₄C₂
- PbO: reaction above 700°C
- MeⁿO: Me= Fe²⁺, Cu²⁺, Ni²⁺, etc., formation of spinels, CaO formation above 1200°C
- Alkaline and alkaline-earth ferrites: melt dissolves Al₂O₃
- Ti-alloys (very high oxygen affinity)
- Reactions with Fe-Ni- and Mg-alloys possible at higher temperatures

Chemical Behavior of Graphite (C)

Critical

- O₂: reaction above 400°C
- N₂: reaction starting at 1700°C (formation of small amounts of cyanides)
- Oxides
- Water vapor
- F₂, Br₂: reaction at room temperature
- Sulfur
- Si: formation of SiC at approx. 1400°C
- Chromic acid
- Chlorosulfonic acid ClSO₃H
- SiO₂: formation of SiC: formation of SiC via intermediate product SiO (technical production of SiC above 1800°C; however, reaction between SiO₂ and C begins at lower temperature).
- Nitrous gases (NO, NO₂)
- Sulfuric acid, H₂SO₄: concentrated acid critical above 150°C, fuming acid already at room temperature
- Nitric acid, HNO₃: diluted acid critical at 90°C, fuming acid already at room temperature
- SO₃: critical above 100°C
- Danger of explosion with perchloric acid, HClO₄
- NaOCl: critical above 50°C



Special Crucibles for Special Applications – BN and ZrO₂

ZrO₂ Crucibles

Due to the higher melting point in comparison to Al₂O₃, the applications temperature is about 2000°C. In an inert or reductive atmosphere, darkening of the crucibles may occur due to oxygen losses (ZrO_{2-x}).

This changes also the absorption of the thermal radiation coming from the furnace. This might also result in lower chemical resistance. Not useful for the melting of Ti or Zr alloys.

BN Crucibles

Not recommended for oxidizing atmospheres. Oxidizes in air at about 800°C.

In the presence of Ar, He, or in vacuum, tungsten embrittles and hardens when in contact with BN. Maximum temperature when in contact with tungsten (W), platinum (Pt), rhodium (Rh) or platinum/rhodium alloys: 1600°C

For other materials which get in contact with boron nitride (BN), the user has to ensure that no reactions occur damaging crucibles or liners. Delivered in a bag with Ar protective atmosphere. Might pick up moisture due to B₂O₃ impurity. It is recommended to store the BN crucibles in a desiccator in an Ar atmosphere after opening the bag.

Suitable for high melting fluorides as LiF, NaF etc.
Also appropriate for Si, MgAl alloys.

Material Compatibility – Sample in Crucible

Material Compatibility

The right crucible must always be chosen for the given experiment. Crucible materials should be specially selected depending on the application and sample materials in order to prevent reactions between the sample and crucible.

These tables serve to indicate which of the common crucible types can be used for each application, including ceramics, metals, inorganics and other more general applications.

General Applications						
Materials/ Crucible Types	Pt/Rh	Al ₂ O ₃	Al	Pt+Al ₂ O ₃ liner	Al ₂ O ₃ crucible sprayed with Y ₂ O ₃	Graphite
Clays	✓	✓*	✓	✓*	✓*	No
Minerals	✓	✓*	✓	✓*	✓*	No
Oxide ceramics	✓	✓*	✓	✓*	✓*	No
Salts	✓	No	✓	No	No	No
Glasses	✓	No	✓	No	No	✓*
Metals	No**	✓	No	✓	✓	No
Polymers	✓	✓	✓	✓	✓	✓
Carbon materials	✓*	✓*	✓	✓*	✓*	✓
Inorganics	✓*	✓*	✓*	✓*	✓*	✓*

Ceramics

Materials/ Crucible Types	Pt/Rh	Al ₂ O ₃	Al	Pt+Al ₂ O ₃ liner	Al ₂ O ₃ crucible sprayed with Y ₂ O ₃	Graphite
Alumina (Al ₂ O ₃)	✓	✓	✓	✓	✓	✓*
Zirconia (ZrO ₂)	✓	✓	✓	✓	✓	✓*
MgO	✓	✓	✓	✓	✓	✓*
Y ₂ O ₃	✓	No	✓	✓	✓	✓*
Silicon dioxide (SiO ₂)	✓	No	✓	No	No	No
Silicon nitride (Si ₃ N ₄)	No	✓*	✓	✓*	✓*	✓*
Aluminum nitride (AlN)	✓*	✓*	✓*	✓*	✓*	✓*
Boron nitride (BN)	✓*	✓*	✓*	✓*	✓*	✓*
Silicon carbide (SiC)	No	✓*		✓*	✓*	✓*
Titanium oxide (TiO ₂)	✓	✓	✓	✓	✓	✓*

Metals

Materials/ Crucible Types	Pt/Rh	Al ₂ O ₃	Al	Pt+Al ₂ O ₃ liner	Al ₂ O ₃ crucible sprayed with Y ₂ O ₃	Graphite
Al and Al-alloys	No**	✓	No	✓	✓	✓
Mg and Mg-alloys	No**	✓*	No	✓*	✓*	✓
Cu and Cu-alloys	No**	✓	No	✓	✓*	✓
Fe and Fe-alloys	No**	✓*	No	✓*	✓	No
Ni and Ni-alloys	No**	✓*	No	✓*	✓	No
Ti and Ti-alloys	No**	✓*	No	✓*	✓	No
Sn and Sn-alloys	No**	✓	No	✓	✓	✓
Au- and Ag-alloys	No**	✓	No	✓	✓	✓*
Cr-, Mo-, Co-alloys	No**	✓*	No	✓*	✓	No

Inorganics

Materials/ Crucible Types	Pt/Rh	Al ₂ O ₃	Al	Pt+Al ₂ O ₃ liner	Al ₂ O ₃ crucible sprayed with Y ₂ O ₃	Graphite
Silicon	No	No	✓	No	No	✓*
Iron oxide	✓	No	✓	No	No	No
Lead oxide	No	✓*		✓*	✓*	No
Magnesium fluoride	✓	No	✓	No	No	No information
Calcium fluoride	✓	No	✓	No	No	✓
Copper oxide	✓	No	✓	No	No	No
Graphites	✓*	✓*	✓*	✓*	✓*	✓
Carbonates	✓	✓*	✓	✓*	✓*	No
Sulphates	✓	✓*	✓	✓*	✓*	No

- ✓ No reaction expected
- ✓* Reactions possible at high temperatures
- No** Not recommended; reactions may occur prior to or during melting.
This could lead to damage to the crucible and/or sensor. Extreme caution advised.

Recommendations for Cleaning Al_2O_3 and Pt Crucibles

Recommendations for Cleaning Al_2O_3 and Pt Crucibles

In most cases, the majority of ceramic and metallic crucibles and their lids can be reused many times. In order to ensure a long lifetime of proper use, the following cleaning recommendations are given for the most common crucibles, made of alumina (Al_2O_3) and platinum (Pt).



Acids must be handled very carefully under a fume hood. Use protective glasses, gloves and apron and read the MSD sheets. Acids should only ever be handled by a person experienced in the handling of chemicals.

All acids (especially HF) are very dangerous and can cause extremely serious injuries or death if they come in contact with the skin or are inhaled.

Work with acids is at the user's own risk. NETZSCH can assume no liability for damage or injury resulting from the use of acids.



Al₂O₃ Crucibles

- **Contamination with organics (polymers, organic pyrolysis products, carbon black, etc.)**
Heat crucibles in air or oxygen to approx. 900°C to burn off the organics. If there are oxide fillers present, be careful with the end temperature, as there might be a reaction with alumina (lower the temperature and work in oxygen). Use a separate furnace, if available.
- **Contamination with metals and alloys**
Clean with HCl acid (concentration 25% or higher). If there is no reaction with the contaminant, heat the beaker with the acid. If HCl alone does not work, use a mixture of HCl/HNO₃ (1:1) (both concentrated). This may be heated as well. oxides, but also the alumina.
- **Oxides and other salts**
Some salts are water soluble. Boil the crucibles in distilled water. Use HCl or a mixture of HCl/HNO₃ (1:1) (both concentrated). Oxides are often very stable or have already reacted with the alumina. It could easily be the case that it is impossible to remove the deposits. In that case, the crucible must be discarded. HF dissolves oxides, but also the alumina.

Following these cleaning procedures, rinse the crucibles several times with distilled water and let them dry at room temperature. Then heat them in a separate furnace in air to 1500°C.

Pt Crucibles

- **Contamination with organics (polymers, etc.)**
Heat crucibles in air or oxygen to approx. 900°C to burn off the organics. If oxide fillers are present, attempt to remove them mechanically or use HF (see next procedure)
- **Contamination with metals and alloys**
There is often no way of removing metals, as Pt will alloy with most metals at higher temperatures. However, make an attempt with HCl acid (concentration 25% or higher). If there is no reaction with the contaminant, try heating the beaker with the acid. Do not use a mixture of HCl/HNO₃ (1:1). This would also dissolve the Pt!
- **Oxides and other salts**
Some salts are water soluble. Boil the crucibles in distilled water. Most oxides can be dissolved in HF. In some cases, it is helpful to warm the acid. Some salts can be dissolved in HCl.

The NETZSCH Group is an owner-managed, international technology company with headquarters in Germany. The Business Units Analyzing & Testing, Grinding & Dispersing and Pumps & Systems represent customized solutions at the highest level. A worldwide sales and service network ensure customer proximity and competent service.

Our performance standards are high. We promise our customers Proven Excellence – exceptional performance in everything we do, proven time and again since 1873.

When it comes to Thermal Analysis, Calorimetry (adiabatic & reaction), the determination of Thermophysical Properties, Rheology and Fire Testing, NETZSCH has it covered. Our 60 years of applications experience, broad state-of-the-art product line and comprehensive service offerings ensure that our solutions will not only meet your every requirement but also exceed your every expectation.

Proven Excellence. ■

NETZSCH-Gerätebau GmbH
Wittelsbacherstraße 42
95100 Selb, Germany
Tel.: +49 9287 881-0
Fax: +49 9287 881-505
at@netsch.com
www.analyzing-testing.netsch.com



Traunstraße 21, A-2120 Wolkersdorf
T: +43 2245 6725 F: +43 2245 559633
office@prager-elektronik.at
www.prager-elektronik.at



NETZSCH®

www.netsch.com